

SINGER
14U595

PARTS LIST

SINGER

14U595

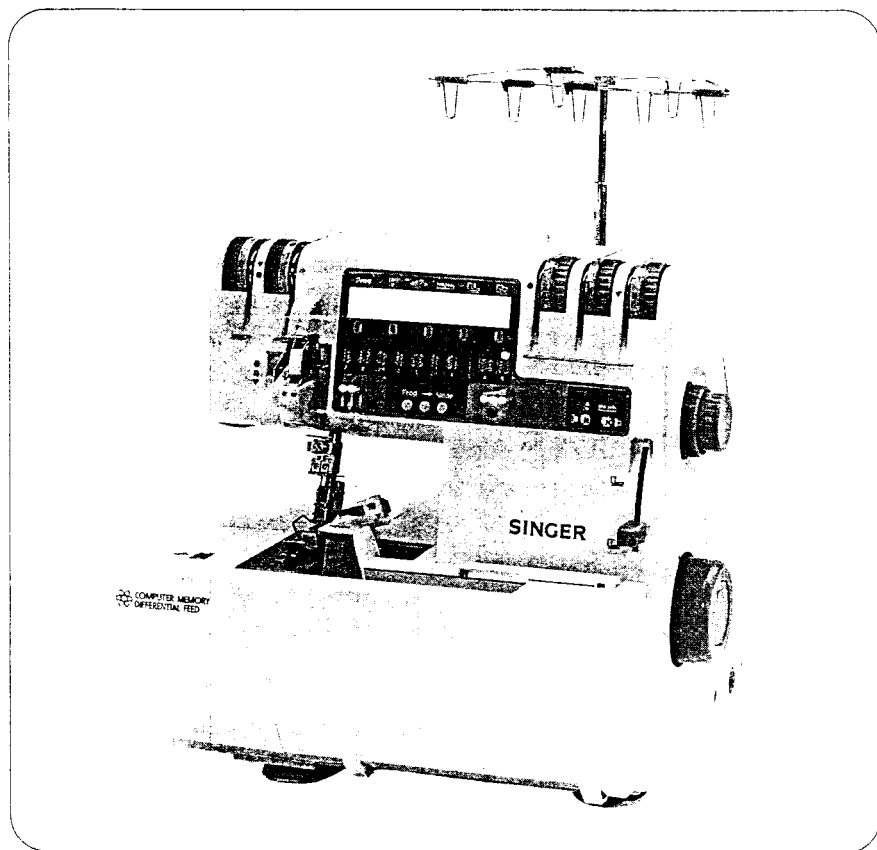

A. MACHINE FRAME

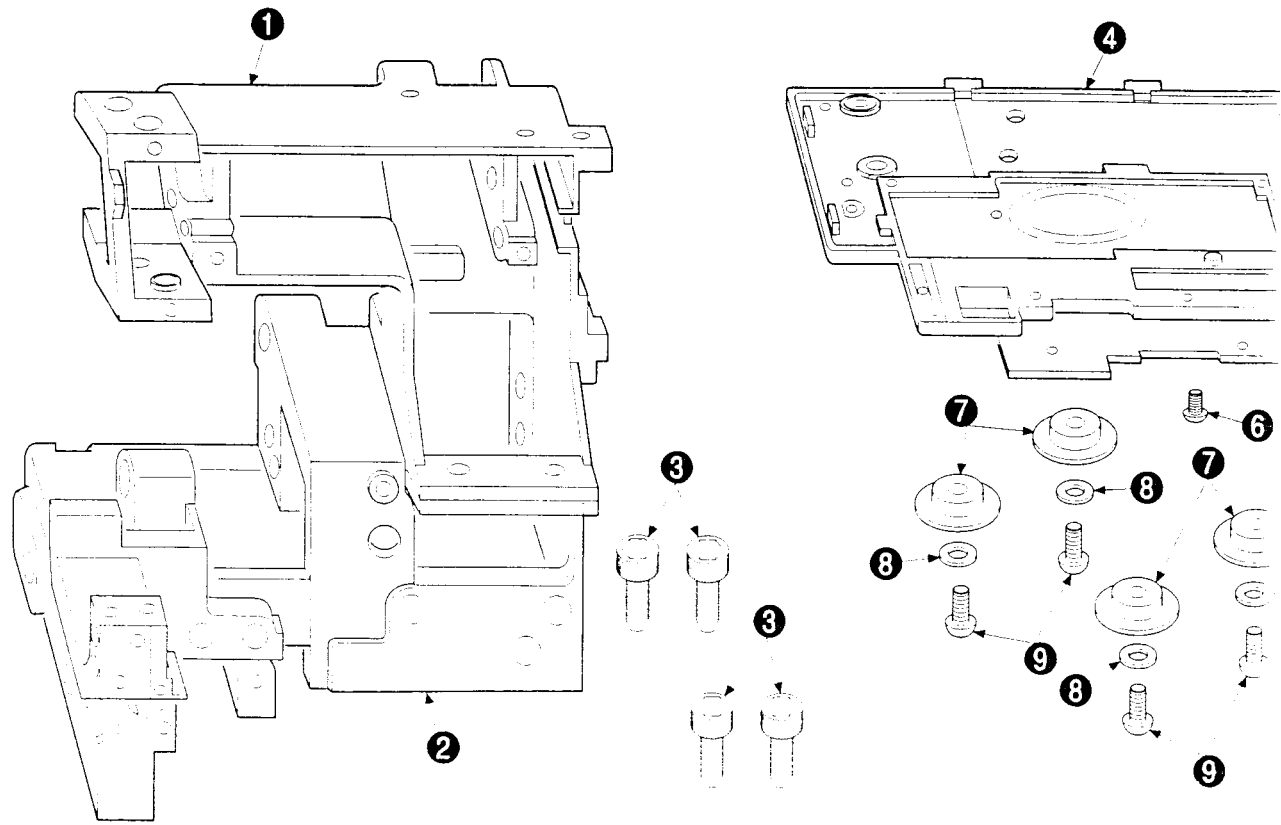

B. MAIN SHAFT MECHANISM

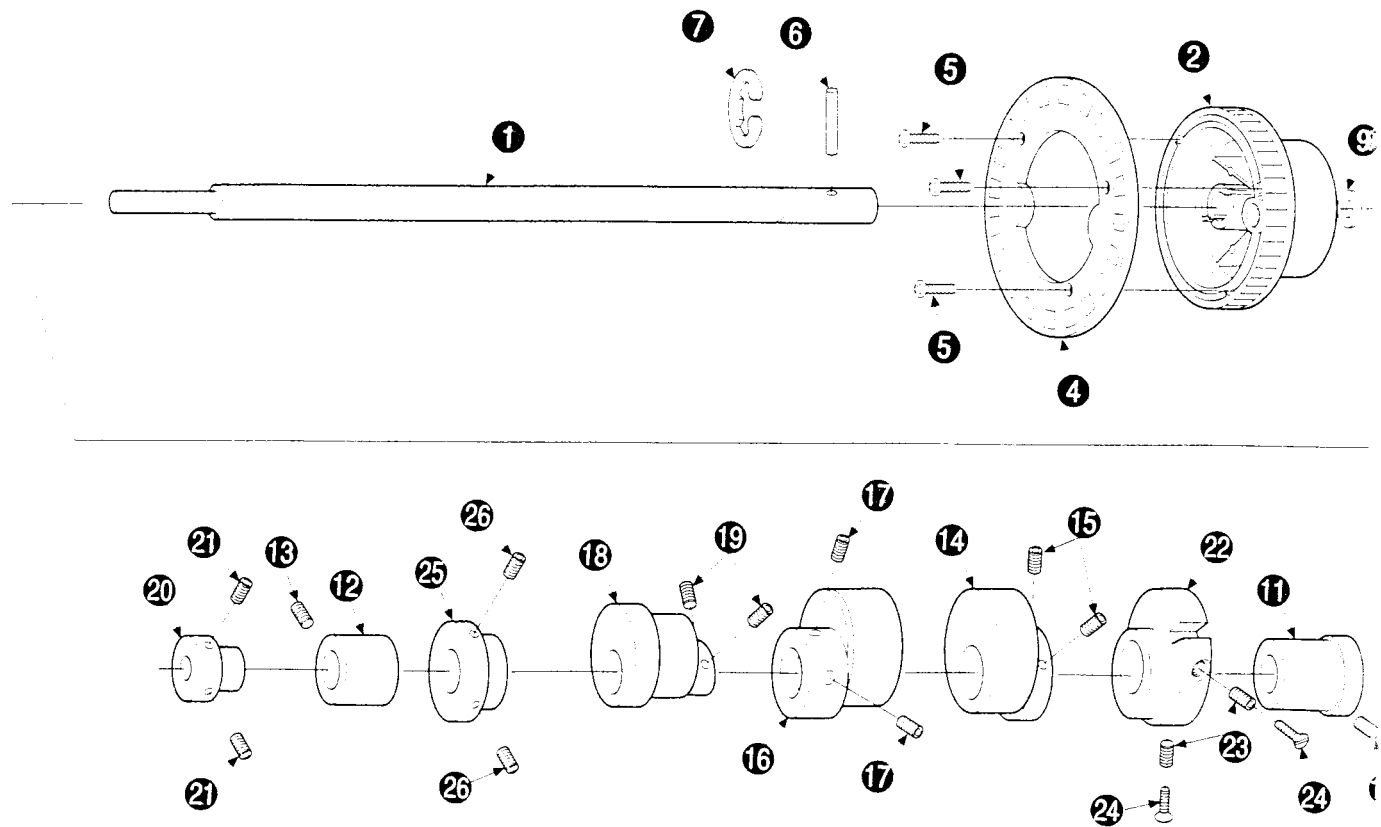

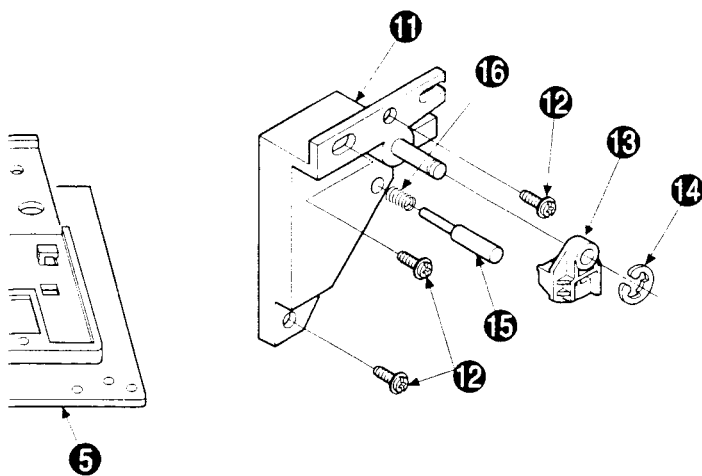

No.	Part No.	Description	Qt.
1	ML350003	Arm	1
2	ML350002	Bed	1
3	ML106228	Arm bed screw	4
4	ML350004	Machine base	1
5	ML350010	Machine base reinforcing plate	1
6	ML106315	Machine base reinforcing plate screw	1
7	ML340012	Cushion rubber	4
8	ML106091	Cushion rubber washer	4
9	ML106208	Cushion rubber screw	4
10	ML106244	Machine base screw	4
11	ML350006	Drive pulley stopper bracket	1
12	ML106242	Drive pulley stopper bracket screw	3
13	ML350007	Drive pulley stop cam	1
14	ML106135	Drive pulley stop cam ring	1
15	ML350008	Drive pulley stop pin	1
16	ML350009	Drive pulley stopper spring	1

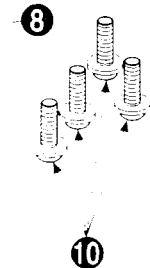

C. NEEDLE DRIVE MECHANISM

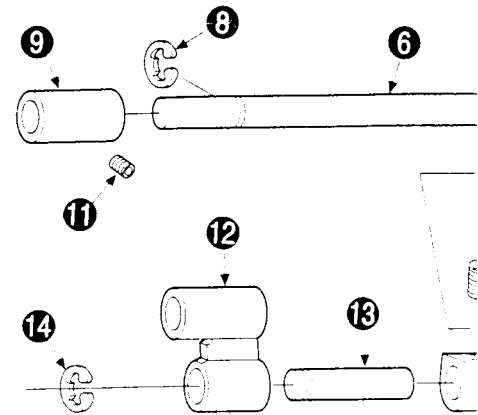

No.	Part No.	Description	Qt.
1	ML350100	Main shaft	1
2	ML350114	Drive pulley	1
3	ML350115	Drive pulley cap	1
4	ML350102	Slit circle plate	1
5	ML106300	Slit circle plate screw	3
6	ML310139	Drive pulley pin	1
7	ML310138	Drive pulley thrust ring	1
8	ML106152	Drive pulley spring washer	1
9	ML106153	Drive pulley washer	1
10	ML106112	Drive pulley screw	1
11	ML320102	Main shaft bushing (Right)	1
12	ML320103	Main shaft bushing (Left)	1
13	ML106226	Main shaft bushing screw	2
14	ML350101	Needle bar drive eccentric	1
15	ML106226	Needle bar drive eccentric screw	2
16	ML350103	Right looper drive eccentric	1
17	ML106226	Right looper drive eccentric screw	2
18	ML350104	Left looper upper knife drive eccentric	1
19	ML106226	Left looper upper knife drive eccentric screw	2
20	ML350107	Double chain looper connecting drive eccentric	1
21	ML106226	Double chain looper connecting drive eccentric screw	2
22	ML350105	Main feed connecting drive eccentric	1
23	ML106226	Main feed connecting drive eccentric screw	2
24	ML106301	Main feed connecting drive eccentric cap screw	2
25	ML350106	Feed lift drive eccentric	1
26	ML106226	Feed lift drive eccentric screw	2

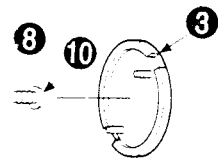

No.	Part No.	Description	Qt.
1	ML340200	Needle bar drive connection	1
2	ML340201	Needle bar drive connection pin	1
3	ML320305	Needle bar drive connection pin ring	1
4	ML106226	Needle bar drive connection pin screw	1
5	ML350200	Needle bar drive arm	1
6	ML350210	Needle bar drive arm pivot shaft	1
7	ML106226	Needle bar drive arm pivot shaft screw	1
8	ML320305	Needle bar drive arm pivot shaft ring	2
9	ML320403	Needle bar drive arm pivot shaft bushing (Left)	1
10	ML320705	Needle bar drive arm pivot shaft bushing (Right)	1
11	ML106226	Needle bar drive arm pivot shaft bushing screw	2
12	ML350211	Needle bar drive link	1
13	ML340201	Needle bar drive link pin	1
14	ML320305	Needle bar drive link pin ring	1
15	ML106226	Needle bar drive link pin screw	1
16	ML350202	Needle thread take up	1
17	ML106211	Needle thread take up screw	1
18	ML350203	Needle bar connecting bracket	1
19	ML106021	Needle bar connecting bracket screw	1
20	ML350204	Needle bar (complete)	1
21	ML350298	Needle clamp thread guide	1
22	ML320210	Needle bar bushing	2
23	ML106226	Needle bar bushing screw	2
24	ML350213	Needle (Cat. No. 2022) # 14	2
25	ML106254	Needle clamp screw	2
26	ML106255	Needle clamp screw	1
27	ML330278	Needle clamp screw indication plate	1
28	ML330274	Needle bar thread retainer disc guide plate	1
29	ML330275	Needle bar thread retainer disc	1
30	ML330276	Needle bar thread retainer disc spring	1
31	ML330277	Needle bar thread retainer disc screw	1

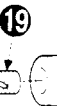

E. UPPER & LOWER KNIFE MECHANISM

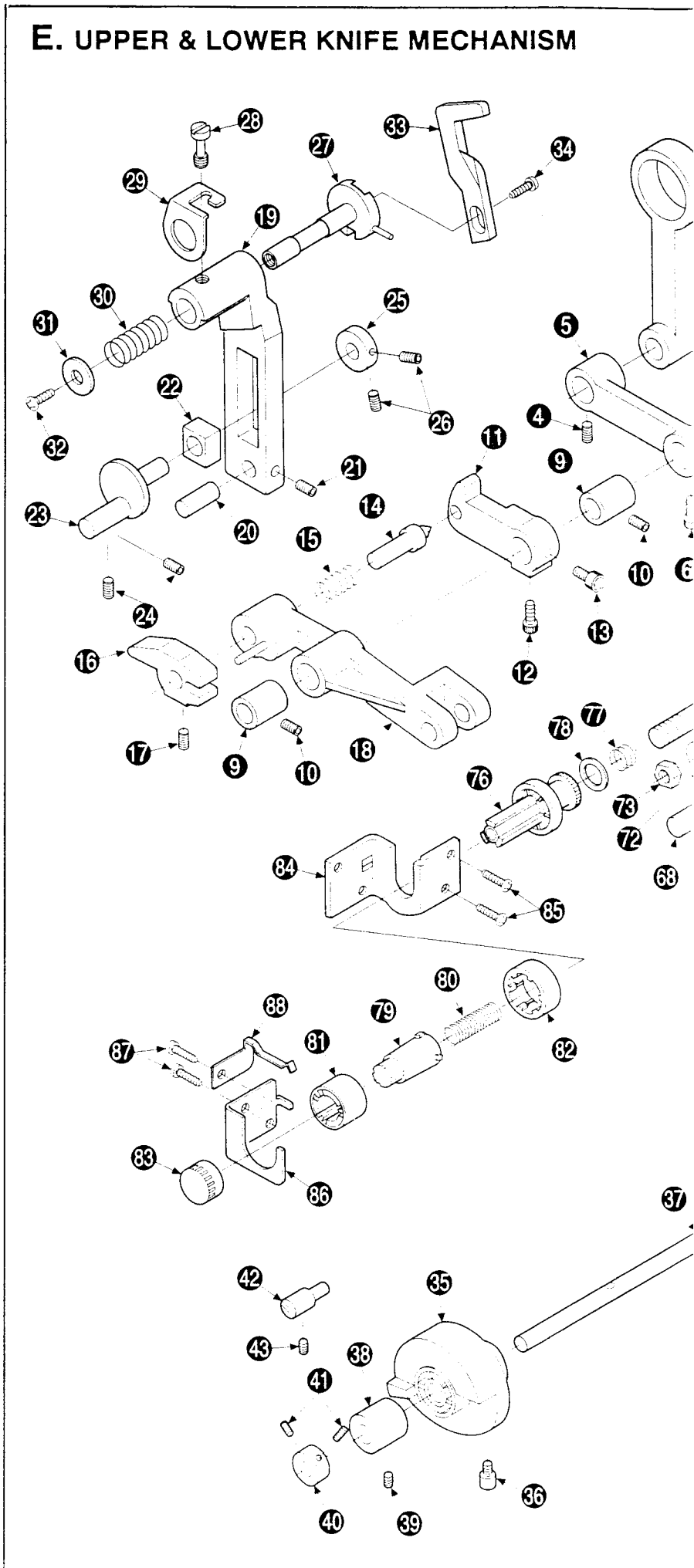
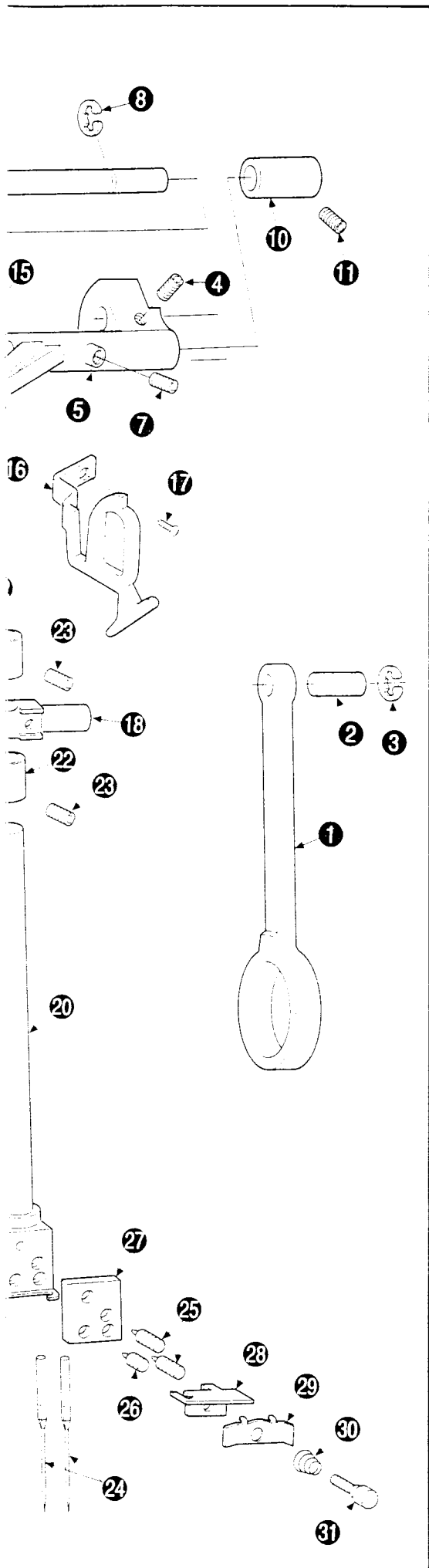

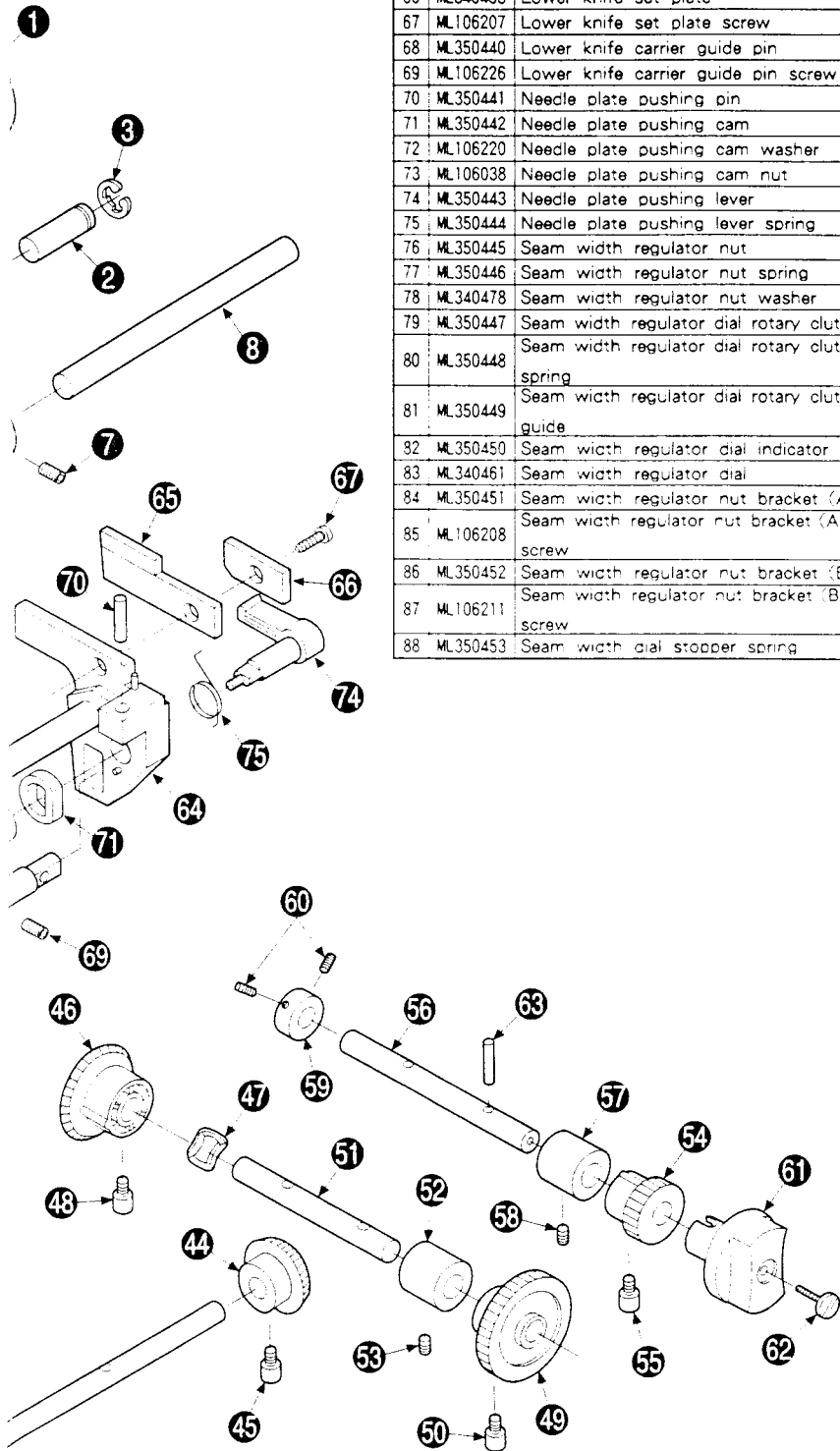

No.	Part No.	Description	Qt.
64	ML350435	Lower knife carrier (complete)	1
65	ML350439	Lower knife	1
66	ML340453	Lower knife set plate	1
67	ML106207	Lower knife set plate screw	1
68	ML350440	Lower knife carrier guide pin	1
69	ML106226	Lower knife carrier guide pin screw	1
70	ML350441	Needle plate pushing pin	1
71	ML350442	Needle plate pushing cam	1
72	ML106220	Needle plate pushing cam washer	1
73	ML106038	Needle plate pushing cam nut	1
74	ML350443	Needle plate pushing lever	1
75	ML350444	Needle plate pushing lever spring	1
76	ML350445	Seam width regulator nut	1
77	ML350446	Seam width regulator nut spring	1
78	ML340478	Seam width regulator nut washer	1
79	ML350447	Seam width regulator dial rotary clutch	1
80	ML350448	Seam width regulator dial rotary clutch spring	1
81	ML350449	Seam width regulator dial rotary clutch guide	1
82	ML350450	Seam width regulator dial indicator	1
83	ML340461	Seam width regulator dial	1
84	ML350451	Seam width regulator nut bracket (A)	1
85	ML106208	Seam width regulator nut bracket (A) screw	2
86	ML350452	Seam width regulator nut bracket (B)	1
87	ML106211	Seam width regulator nut bracket (B) screw	2
88	ML350453	Seam width dial stopper spring	1

No.	Part No.	Description	Qt.
1	ML350400	Upper knife drive connection	1
2	ML330225	Upper knife drive connection pin	1
3	ML310699	Upper knife drive connection pin ring	1
4	ML106226	Upper knife drive connection pin screw	1
5	ML350401	Upper knife drive crank	1
6	ML106321	Upper knife drive crank screw	1
7	ML106226	Upper knife drive crank screw	1
8	ML350402	Upper knife drive crank shaft	1
9	ML320403	Upper knife drive crank shaft bushing	2
10	ML106226	Upper knife drive crank shaft bushing screw	2
11	ML350403	Upper knife clutch crank	1
12	ML106321	Upper knife clutch crank screw	1
13	ML106327	Upper knife clutch crank screw	1
14	ML350404	Upper knife clutching pin	1
15	ML350425	Upper knife clutching pin spring	1
16	ML350405	Upper knife clutching guide	1
17	ML106226	Upper knife clutching guide screw	1
18	ML350406	Upper knife lever drive arm	1
19	ML350407	Upper knife lever	1
20	ML330301	Upper knife lever pin	1
21	ML106226	Upper knife lever pin screw	1
22	ML340331	Upper knife lever drive slider	1
23	ML350408	Upper knife lever eccentric pin	1
24	ML106226	Upper knife lever eccentric pin screw	2
25	ML350409	Upper knife lever eccentric pin collar	1
26	ML106226	Upper knife lever eccentric pin collar screw	2
27	ML350410	Upper knife carrier	1
28	ML106308	Upper knife carrier screw	1
29	ML350411	Upper knife carrier screw bracket	1
30	ML350412	Upper knife spring	1
31	ML106091	Upper knife spring set plate	1
32	ML106207	Upper knife spring set plate screw	1
33	ML350414	Upper knife	1
34	ML106207	Upper knife screw	1
35	ML350415	Upper knife clutching cam	1
36	ML106309	Upper knife clutching cam screw	1
37	ML350416	Upper knife clutching cam shaft	1
38	ML320403	Upper knife clutching cam shaft bushing	1
39	ML106226	Upper knife clutching cam shaft bushing screw	1
40	ML340633	Upper knife clutching cam shaft collar	1
41	ML106226	Upper knife clutching cam shaft collar screw	2
42	ML350426	Upper knife clutching cam stop pin	1
43	ML106226	Upper knife clutching cam stop pin screw	1
44	ML350417	Upper knife clutching gear A	1
45	ML106309	Upper knife clutching gear A screw	1
46	ML350418	Upper knife clutching gear B	1
47	ML330357	Upper knife clutching gear B wave washer	1
48	ML106309	Upper knife clutching gear B screw	1
49	ML350419	Upper knife clutching gear C	1
50	ML106309	Upper knife clutching gear C screw	1
51	ML350420	Upper knife clutching gear pin	1
52	ML320705	Upper knife clutching gear pin bushing	1
53	ML106226	Upper knife clutching gear pin bushing screw	1
54	ML350421	Upper knife clutch operating gear	1
55	ML106309	Upper knife clutch operating gear screw	1
56	ML350422	Upper knife clutch operating gear pin	1
57	ML320705	Upper knife clutch operating gear pin bushing	1
58	ML106226	Upper knife clutch operating gear pin bushing screw	1
59	ML340212	Upper knife clutch operating gear pin collar	1
60	ML106261	Upper knife clutch operating gear pin collar screw	2
61	ML350423	Upper knife clutching dial	1
62	ML106311	Upper knife clutching dial screw	1
63	ML350424	Upper knife clutching dial stop pin	1

D. FEED MECHANISM

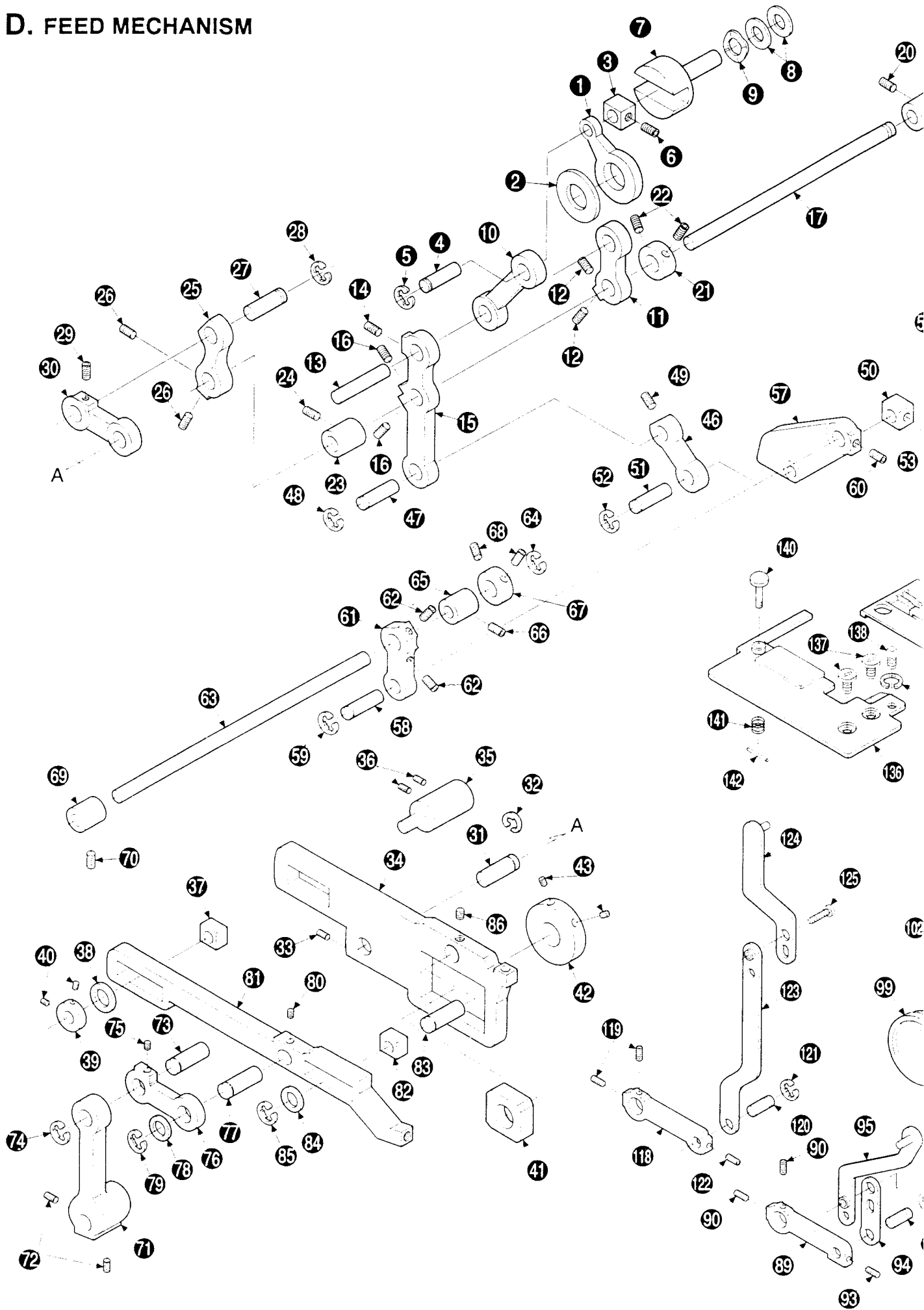

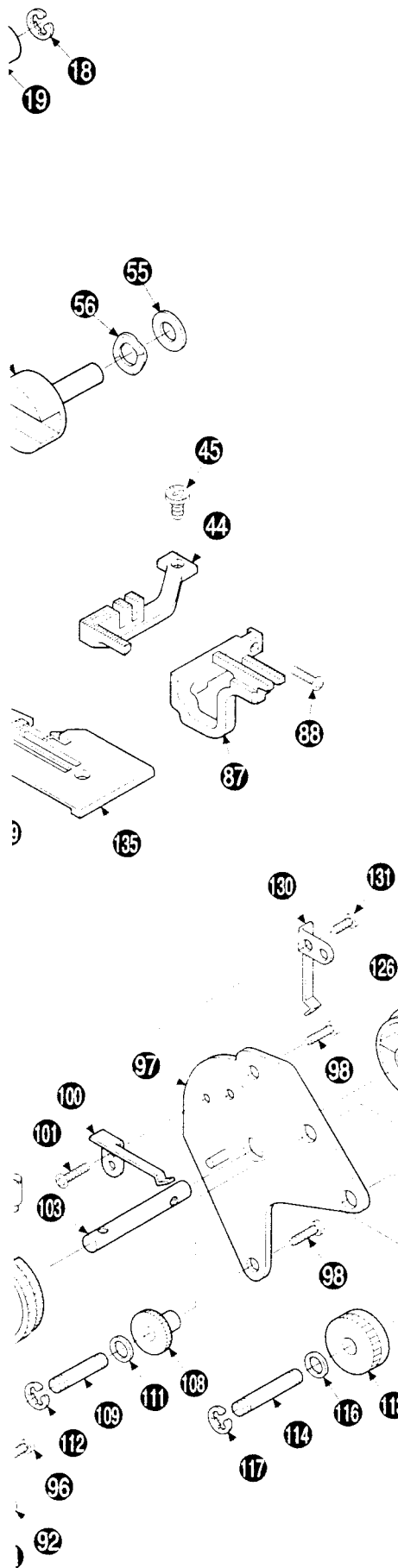

No.	Part No.	Description	Qt.
1	ML350318	Feed connecting rod	1
2	ML340401	Feed connecting rod swing stopper	1
3	ML350319	Feed connecting drive slider	1
4	ML330572	Feed connecting drive slider pin	1
5	ML106135	Feed connecting drive slider pin ring	1
6	ML106226	Feed connecting drive slider pin screw	1
7	ML350320	Feed regulator	1
8	ML106134	Feed regulator washer	2
9	ML330357	Feed regulator wave washer	1
10	ML350321	Feed connecting drive crank	1
11	ML350334	Feed connecting drive crank fixing rod	1
12	ML106226	Feed connecting drive crank fixing rod screw	2
13	ML330301	Feed connecting drive crank fixing rod pin	1
14	ML106226	Feed connecting drive crank fixing rod pin screw	1
15	ML350322	Feed connecting link	1
16	ML106226	Feed connecting link screw	2
17	ML350323	Feed connecting link shaft	1
18	ML320305	Feed connecting link shaft ring	1
19	ML320403	Feed connecting link shaft bushing (right)	1
20	ML106226	Feed connecting link shaft bushing (right) screw	1
21	ML340633	Feed connecting link shaft collar	1
22	ML106226	Feed connecting link shaft collar screw	2
23	ML320705	Feed connecting link shaft bushing (left)	1
24	ML106261	Feed connecting link shaft bushing (left) screw	1
25	ML350324	Main feed drive link	1
26	ML106226	Main feed drive link screw	2
27	ML340336	Main feed drive link pin	1
28	ML106135	Main feed drive link pin ring	1
29	ML106226	Main feed drive link pin screw	1
30	ML350326	Main feed connecting rod	1

No.	Part No.	Description	Qt.
31	ML340336	Main feed connecting rod pin	1
32	ML106135	Main feed connecting rod pin ring	1
33	ML106226	Main feed connecting rod pin screw	1
34	ML350327	Main feed bar	1
35	ML350328	Feed bar hinge pin	1
36	ML106226	Feed bar hinge pin screw	2
37	ML350329	Feed bar connecting drive slider	1
38	ML106153	Feed bar connecting drive slider washer	1
39	ML340615	Feed bar connecting drive slider collar	1
40	ML106226	Feed bar connecting drive slider collar screw	2
41	ML340366	Feed bar drive slider	1
42	ML330395	Feed bar swing stopper	1
43	ML106226	Feed bar swing stopper screw	2
44	ML350330	Main feed dog	1
45	ML106207	Main feed dog screw	1
46	ML350331	Differential drive crank	1
47	ML340336	Differential drive pin	1
48	ML106135	Differential drive pin ring	1
49	ML106226	Differential drive pin screw	1
50	ML350319	Differential connecting drive slider	1
51	ML350332	Differential connecting drive slider pin	1
52	ML106135	Differential connecting drive slider pin ring	1
53	ML106226	Differential connecting drive slider pin screw	1
54	ML350320	Differential feed ratio regulator	1
55	ML106134	Differential feed ratio regulator washer	1
56	ML330357	Differential feed ratio regulator wave washer	1
57	ML350333	Differential drive link	1
58	ML331511	Differential drive link pin	1
59	ML106135	Differential drive link pin ring	1
60	ML106226	Differential drive link pin screw	1
61	ML350334	Differential feed connecting link	1
62	ML106226	Differential feed connecting link screw	1
63	ML350335	Differential feed drive link shaft	1
64	ML320305	Differential feed drive link shaft ring	1
65	ML320705	Differential feed drive link shaft bushing (right)	1
66	ML106226	Differential feed drive link shaft bushing (right) screw	1
67	ML340633	Differential feed drive link shaft collar	1
68	ML106226	Differential feed drive link shaft collar screw	1
69	ML320705	Differential feed drive link shaft bushing (left)	1
70	ML106226	Differential feed drive link shaft bushing (left) screw	1
71	ML350336	Differential feed drive link	1
72	ML106226	Differential feed drive link screw	1
73	ML340336	Differential feed connecting drive link pin	1
74	ML106135	Differential feed connecting drive link pin ring	1
75	ML106226	Differential feed connecting drive link pin screw	1
76	ML350326	Differential feed connecting rod	1
77	ML340336	Differential feed connecting rod pin	1
78	ML106131	Differential feed connecting rod pin washer	1
79	ML106135	Differential feed connecting rod pin ring	1
80	ML106226	Differential feed connecting rod pin screw	1
81	ML350337	Differential feed bar	1
82	ML340331	Differential feed bar connecting drive slider	1
83	ML340336	Differential feed bar connecting drive slider pin	1
84	ML106131	Differential feed bar connecting drive slider pin washer	1

No.	Part No.	Description	Qt.
85	ML106135	Differential feed bar connecting drive slider pin ring	1
86	ML106226	Differential feed bar connecting drive slider pin screw	1
87	ML350338	Differential feed dog	1
88	ML106207	Differential feed dog screw	1
89	ML350300	Feed regulating crank	1
90	ML106226	Feed regulating crank screw	2
91	ML340329	Feed regulating crank pin	1
92	ML106135	Feed regulating crank pin ring	1
93	ML106226	Feed regulating crank pin screw	1
94	ML350301	Main feed adjusting link	1
95	ML350302	Main feed regulator link	1
96	ML106208	Main feed regulator link screw	1
97	ML350303	Dial base plate	1
98	ML106208	Dial base plate screw	2
99	ML350305	Main feed regulating cam	1
100	ML350306	Main feed regulating cam spring	1
101	ML106302	Main feed regulating cam spring screw	1
102	ML106232	Main feed regulating cam screw	1
103	ML350307	Main feed regulating cam pin	1
104	ML330418	Main feed regulating cam pin wave washer	1
105	ML106153	Main feed regulating cam pin washer	1
106	ML350308	Feed adjusting dial	1
107	ML106242	Feed adjusting dial screw	1
108	ML350309	Feed intermediate gear	1
109	ML350310	Feed intermediate gear pin	1
110	ML106037	Feed intermediate gear pin wave washer	2
111	ML106131	Feed intermediate gear pin washer	2
112	ML106135	Feed intermediate gear pin ring	2
113	ML350311	Stitch length indication dial	1
114	ML350310	Stitch length indication dial pin	1
115	ML106037	Stitch length indication dial pin wave washer	1
116	ML106131	Stitch length indication dial pin washer	2
117	ML106135	Stitch length indication dial pin ring	2
118	ML350312	Differential feed regulator crank	1
119	ML106226	Differential feed regulator crank screw	2
120	ML340329	Differential feed regulator crank pin	1
121	ML106135	Differential feed regulator crank pin ring	1
122	ML106226	Differential feed regulator crank pin screw	1
123	ML350313	Differential feed ratio adjusting link	1
124	ML350314	Differential feed ratio regulator link	1
125	ML106208	Differential feed ratio regulator link screw	1
126	ML350315	Differential feed ratio regulator cam	1
127	ML106303	Differential feed ratio regulator cam wave washer	1
128	ML106304	Differential feed ratio regulator cam washer	1
129	ML106305	Differential feed ratio regulator cam ring	1
130	ML350306	Differential feed ratio regulator cam spring	1
131	ML106302	Differential feed ratio regulator cam spring screw	1
132	ML350316	Differential feed ratio adjusting dial	1
133	ML350309	Differential feed intermediate gear	1
134	ML350317	Differential feed ratio indication dial	1
135	ML350350	Needle plate (complete)	1
136	ML350365	Needle plate base	1
137	ML106208	Needle plate base screw	2
138	ML350357	Needle plate fixing pin	1
139	ML350358	Needle plate fixing pin spring	1
140	ML350366	Needle plate guide pin	1
141	ML350367	Needle plate guide pin spring	1
142	ML350736	Needle plate guide pin spring stop pin	1

F. PRESSER FOOT MECHANISM

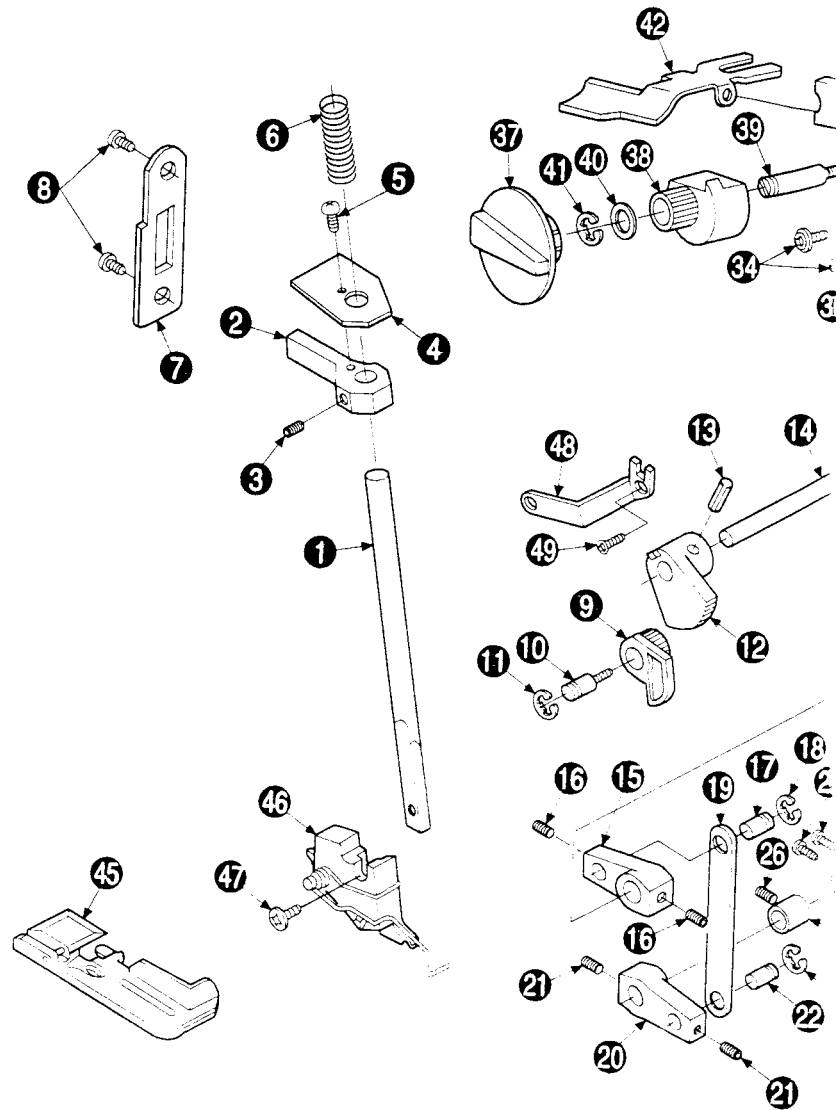

No.	Part No.	Description	Qt.
1	ML340500	Presser foot bar	1
2	ML350539	Presser foot bar guide bracket	1
3	ML106226	Presser foot bar guide bracket screw	1
4	ML350540	Presser foot lifting guide plate	1
5	ML106211	Presser foot lifting guide plate screw	1
6	ML350502	Presser foot pressure spring	1
7	ML350503	Presser foot bar guide	1
8	ML106208	Presser foot bar guide screw	2
9	ML350504	Presser foot lifting cam	1
10	ML350505	Presser foot lifting cam pin	1
11	ML320305	Presser foot lifting cam ring	1
12	ML340552	Presser foot sector gear	1
13	ML106259	Presser foot sector gear pin	1
14	ML350506	Presser foot sector gear shaft	1
15	ML350507	Presser foot sector gear crank	1
16	ML106226	Presser foot sector gear crank screw	2
17	ML340329	Presser foot sector gear crank pin	1
18	ML106135	Presser foot sector gear crank pin ring	1
19	ML350508	Presser foot lifting rod	1
20	ML350507	Presser foot lifting link	1
21	ML106226	Presser foot lifting link screw	2
22	ML340329	Presser foot lifting link pin	1
23	ML106135	Presser foot lifting link pin ring	1
24	ML350509	Presser foot lifting hand lever pin	1
25	ML320403	Presser foot lifting hand lever pin bushing	1
26	ML106226	Presser foot lifting hand lever pin bushing screw	1
27	ML320305	Presser foot lifting hand lever pin ring	1

No.	Part No.	Description
28	ML350510	Presser foot lifting
29	ML106207	Presser foot lifting screw
30	ML350544	Presser foot lifting
31	ML106245	Presser foot lifting
32	ML350543	Presser foot lifting
33	ML350513	Lamp base
34	ML106242	Lamp base screw
35	ML106133	Lamp base washer
36	ML106207	Lamp base screw
37	ML350545	Presser foot pressure
38	ML350515	Presser foot pressure
39	ML106310	Presser foot pressure screw
40	ML106134	Presser foot pressure washer
41	ML320305	Presser foot pressure ring
42	ML350516	Presser foot pressure
43	ML350517	Presser foot pressure pin
44	ML106257	Presser foot pressure pin ring
45	ML350519	Presser foot
46	ML340567	Presser foot shark
47	ML106008	Presser foot shark
48	ML350520	Thread tension disc
49	ML106209	Thread tension disc screw

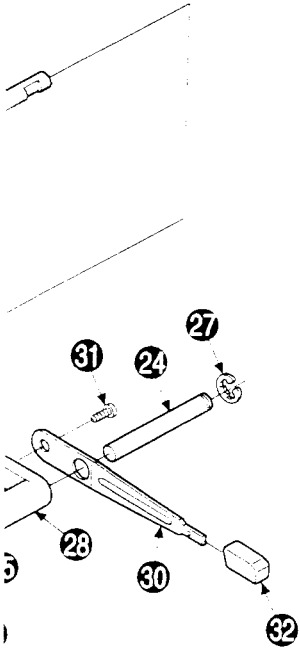
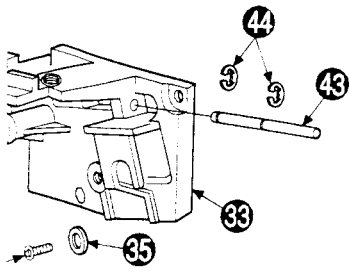

No.	Qt.
1	1
2	2
3	1
4	1
5	1
6	2
7	1
8	1
9	1
10	1
11	1
12	1
13	1
14	1
15	1
16	1
17	1
18	1
19	1
20	1
21	1
22	1
23	1
24	1
25	1
26	1
27	1
28	1
29	1
30	1
31	1
32	1
33	1
34	1
35	1
36	1
37	1
38	1
39	1
40	1
41	1
42	1
43	1
44	1
45	1
46	1
47	1
48	1
49	1
50	1
51	1
52	1
53	1
54	1
55	1
56	1
57	1
58	1
59	1
60	1
61	1
62	1
63	1
64	1
65	1
66	1
67	1
68	1
69	1
70	1
71	1
72	1
73	1
74	1
75	1
76	1
77	1
78	1
79	1
80	1
81	1
82	1
83	1
84	1
85	1
86	1
87	1
88	1
89	1
90	1
91	1
92	1
93	1
94	1
95	1
96	1
97	1
98	1
99	1
100	1

G. LEFT LOOPER DRIVE MECHANISM

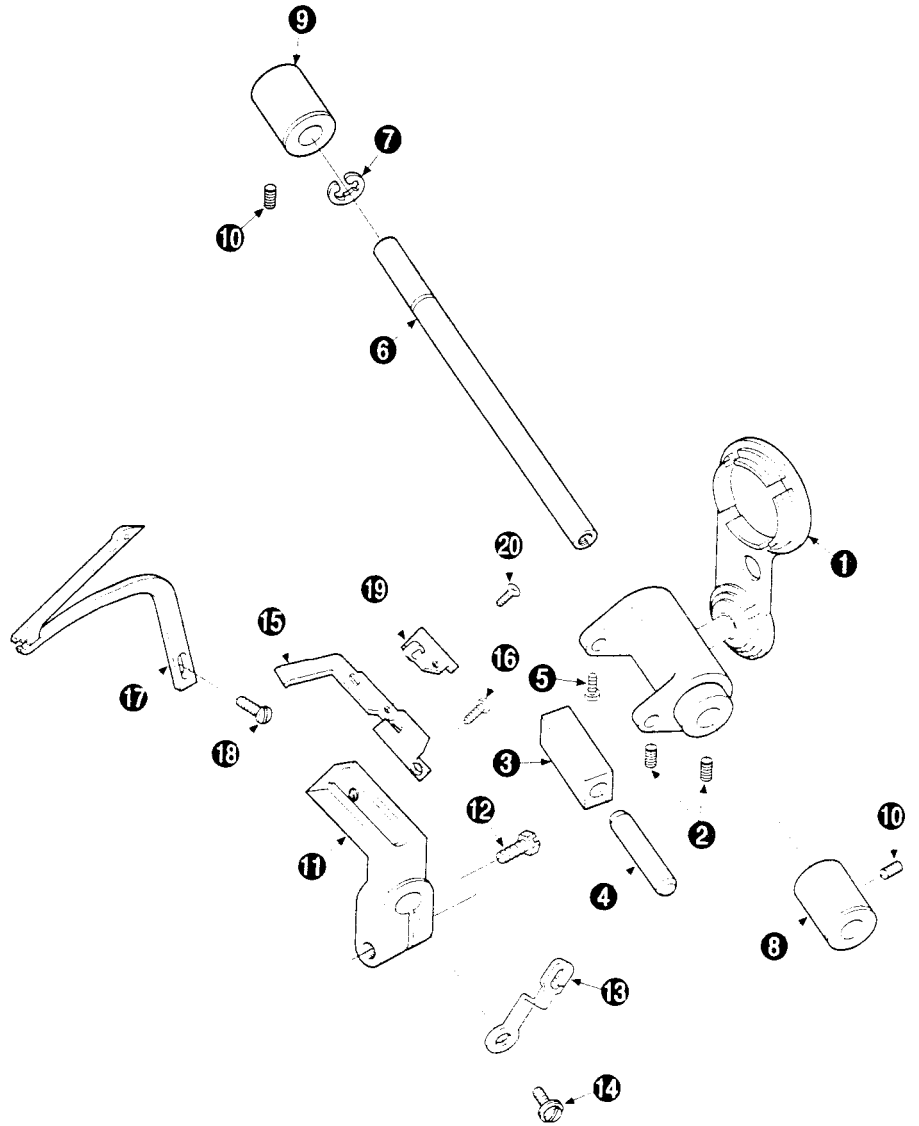

No.	Part No.	Description	Qt.
1	ML350647	Left looper drive crank (complete)	1
2	ML106226	Left looper drive crank (complete) screw	2
3	ML330677	Double chain looper drive slider	1
4	ML330678	Double chain looper drive slider pin	1
5	ML106211	Double chain looper drive slider pin screw	1
6	ML350648	Left looper drive crank shaft	1
7	ML320305	Left looper drive crank shaft ring	1
8	ML320403	Left looper drive crank shaft bushing	1
9	ML320705	Left looper drive crank shaft bushing	1
10	ML106226	Left looper drive crank shaft bushing screw	2
11	ML350607	Left looper lever	1
12	ML106201	Left looper lever screw	1
13	ML350608	Left looper lever thread guide	1
14	ML106245	Left looper lever thread guide screw	1
15	ML350642	Needle guard (rear)	1
16	ML106211	Needle guard (rear) screw	1
17	ML350601	Left looper	1
18	ML106208	Left looper screw	1
19	ML350611	Left looper thread guide	1
20	ML106319	Left looper thread guide screw	1

I. DOUBLE CHAIN LOOPER DRIVE MECHANISM

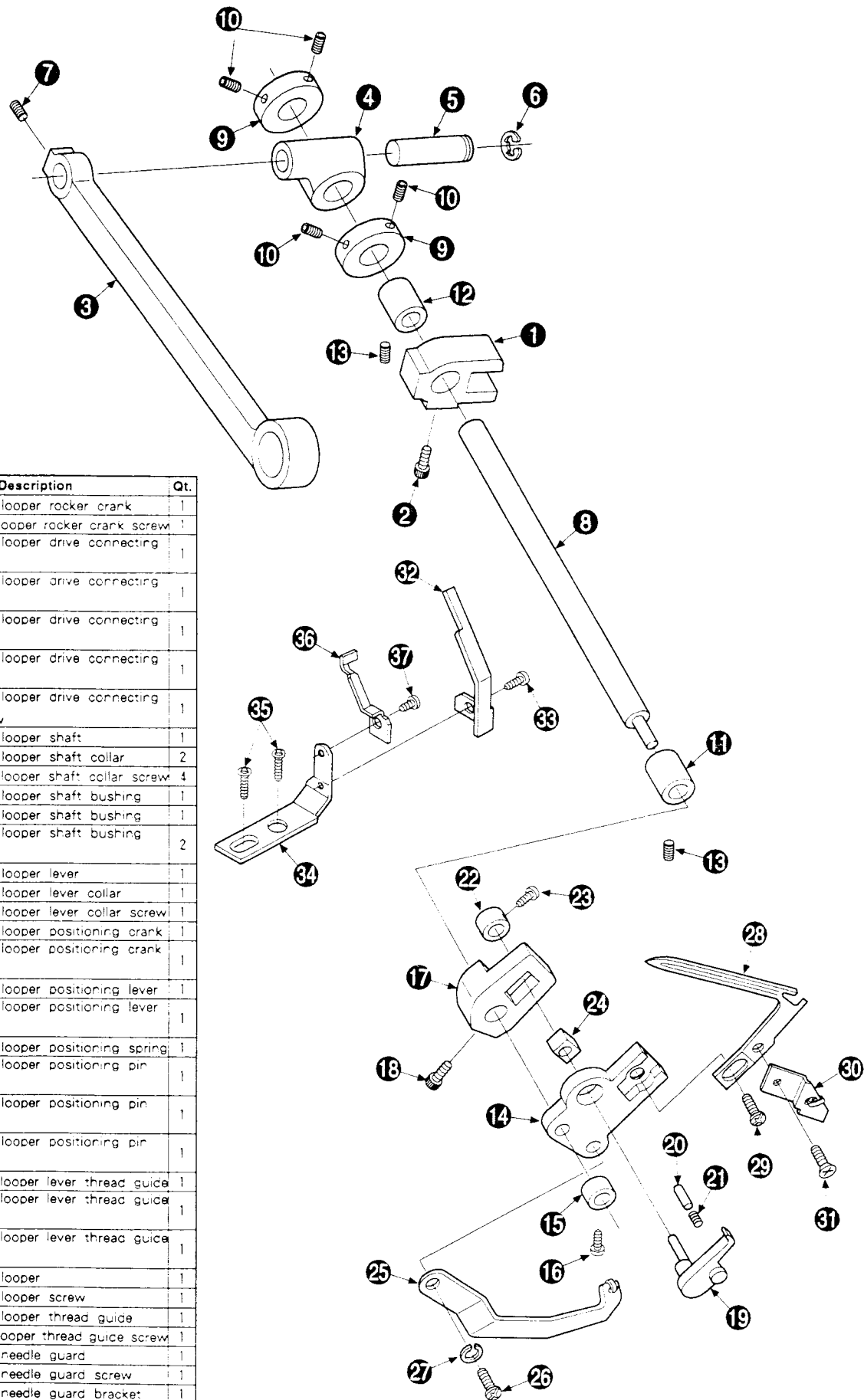

No.	Part No.	Description	Qt.
1	ML350626	Double chain looper rocker crank	1
2	ML106321	Double chain looper rocker crank screw	1
3	ML350627	Double chain looper drive connecting rod	1
4	ML320702	Double chain looper drive connecting rod link	1
5	ML310706	Double chain looper drive connecting rod link pin	1
6	ML310699	Double chain looper drive connecting rod link ring	1
7	ML106226	Double chain looper drive connecting rod link screw	1
8	ML350628	Double chain looper shaft	1
9	ML340633	Double chain looper shaft collar	2
10	ML106225	Double chain looper shaft collar screw	4
11	ML320403	Double chain looper shaft bushing	1
12	ML320705	Double chain looper shaft bushing	1
13	ML106226	Double chain looper shaft bushing screw	2
14	ML350629	Double chain looper lever	1
15	ML350634	Double chain looper lever collar	1
16	ML106211	Double chain looper lever collar screw	1
17	ML350630	Double chain looper positioning crank	1
18	ML106321	Double chain looper positioning crank screw	1
19	ML350631	Double chain looper positioning lever	1
20	ML350632	Double chain looper positioning lever stopper	1
21	ML350633	Double chain looper positioning spring	1
22	ML350634	Double chain looper positioning pin collar	1
23	ML106211	Double chain looper positioning pin collar screw	1
24	ML350635	Double chain looper positioning pin slider	1
25	ML350636	Double chain looper lever thread guide	1
26	ML106208	Double chain looper lever thread guide screw	1
27	ML106124	Double chain looper lever thread guide spring washer	1
28	ML350603	Double chain looper	1
29	ML106208	Double chain looper screw	1
30	ML350637	Double chain looper thread guide	1
31	ML106319	Double chain looper thread guide screw	1
32	ML350638	Double chain needle guard	1
33	ML106312	Double chain needle guard screw	1
34	ML350641	Double chain needle guard bracket	1
35	ML106208	Double chain needle guard bracket screw	2
36	ML350640	Needle guard (front)	1
37	ML106312	Needle guard (front) screw	1

H. RIGHT LOOPER DRIVE MECHANISM

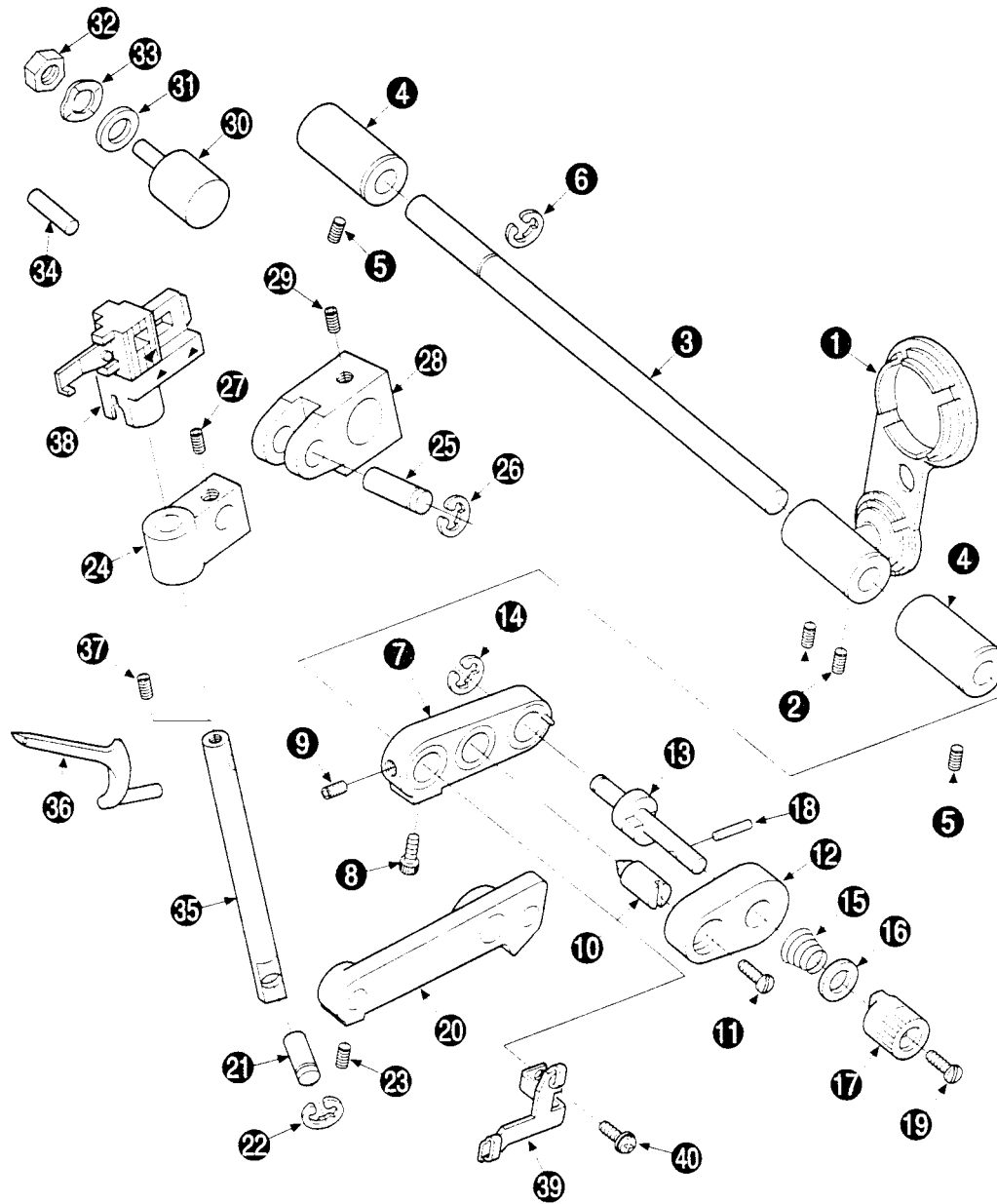

No.	Part No.	Description	Qt.
1	ML340662	Right looper drive crank (complete)	1
2	ML106226	Right looper drive crank (complete) screw	2
3	ML350612	Right looper drive crank shaft	1
4	ML320705	Right looper drive crank shaft bushing	2
5	ML106226	Right looper drive crank shaft bushing screw	2
6	ML320305	Right looper drive crank shaft ring	1
7	ML350613	Right looper clutch crank	1
8	ML106321	Right looper clutch crank screw	1
9	ML106226	Right looper clutch crank screw	1
10	ML350614	Right looper clutching pin	1
11	ML106311	Right looper clutching pin screw	1
12	ML350615	Right looper clutching guide	1
13	ML350616	Right looper clutching cam pin	1
14	ML106139	Right looper clutching cam pin ring	1
15	ML350617	Right looper clutching cam pin spring	1
16	ML106133	Right looper clutching cam pin washer	1
17	ML350618	Right looper clutching dial	1
18	ML350736	Right looper clutching dial stop pin	1
19	ML106311	Right looper clutching dial screw	1
20	ML350619	Right looper drive arm	1
21	ML330658	Right looper drive connection pin	1

No.	Part No.	Description	Qt.
22	ML106139	Right looper drive connection pin ring	1
23	ML106226	Right looper drive connection pin screw	1
24	ML350620	Right looper slider link	1
25	ML331511	Right looper slider link pin	1
26	ML106135	Right looper slider link pin ring	1
27	ML106226	Right looper slider link pin screw	1
28	ML350621	Right looper slider link bracket	1
29	ML106226	Right looper slider link bracket screw	1
30	ML350622	Right looper slider link bracket pin	1
31	ML106014	Right looper slider link bracket pin washer	1
32	ML310656	Right looper slider link bracket pin nut	1
33	ML106037	Right looper slider link bracket pin wave washer	1
34	ML340407	Right looper slider link bracket guide pin	1
35	ML340612	Right looper lever	1
36	ML350602	Right looper	1
37	ML106226	Right looper screw	1
38	ML350623	Two thread convertor (complete)	1
39	ML350625	Looper thread take - up	1
40	ML106245	Looper thread take - up screw	1

K. MOTOR & LIG

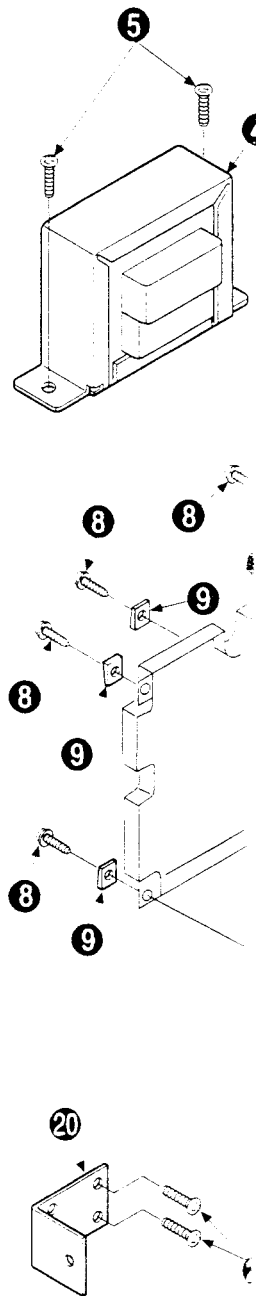

No.	Part No.	Description
1	ML350862	Motor (complete)
2	ML350860	Motor (complete)
3	ML350846	Timing belt
4	ML350810	Transform 230V
	ML350826	Transform 120V
5	ML106315	Transform screw
6	ML350837	LCD board (complete)
	ML350838	LCD board (complete)
7	ML350836	Oil cover
8	ML106326	LCD board screw
9	ML350816	Spacer
10	ML350868	Switch button ; D/C
11	ML350868	Switch button ; D/C
12	ML350817	Connecting cord
13	ML350800	Power board box
	ML350827	Power board box
14	ML106317	Power board box screw
15	ML350874	Power switch button
16	ML350819	Sensor wiring board
17	ML106326	Sensor wiring board

ITING

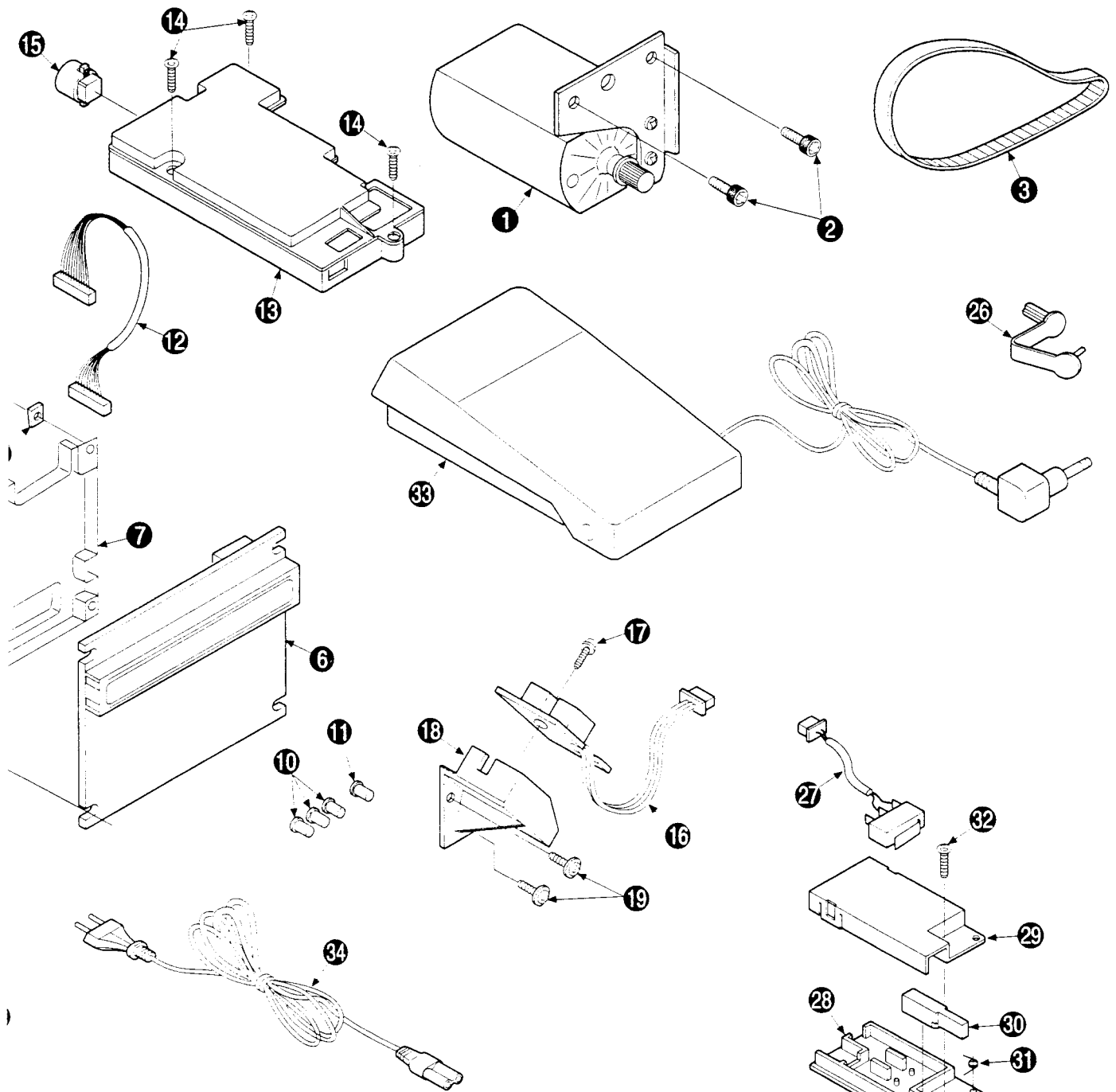

on	Qt.
0~240V	1
120V	(1)
	2
	1
	1
	(1)
	2
230V	1
120V	(1)
	1
	4
	4
3260	3
3266	1
	1
complete) 230V	1
complete) 120V	(1)
120V	3
complete)	1
	1
screw	1

No.	Part No.	Description	Qt.
18	ML350820	Sensor cover	1
19	ML106322	Sensor cover screw	2
20	ML350833	Sensor cover bracket	1
21	ML106208	Sensor cover bracket screw	2
22	ML350811	Lamp socket (complete)	1
23	ML350812	Bulb	1
24	ML350853	Reflector	1
25	ML106242	Reflector screw	1
26	ML340804	Speed clamp	1
27	ML350814	Microswitch (complete)	1
28	ML331861	Switch box (bottom)	1
29	ML331862	Switch box (cover)	1
30	ML331863	Switch box (pin)	1
31	ML331864	Switch box (spring)	1
32	ML106262	Switch box screw	1
33	ML350870	Foot control	1
34	ML350821	Power supply cord EC : 230V VERSION	1
	ML350829	Power supply cord USA, CANADA : 120V VERSION	(1)
	ML350840	Power supply cord UK : 240V VERSION	(1)
	ML350841	Power supply cord AUSTRALIA : 240V VERSION	(1)

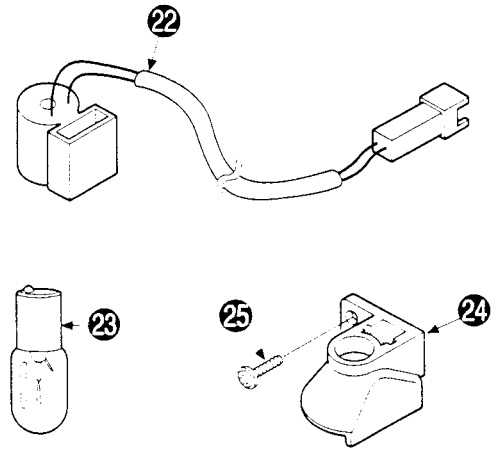

J. MISCELLANEOUS COVERS

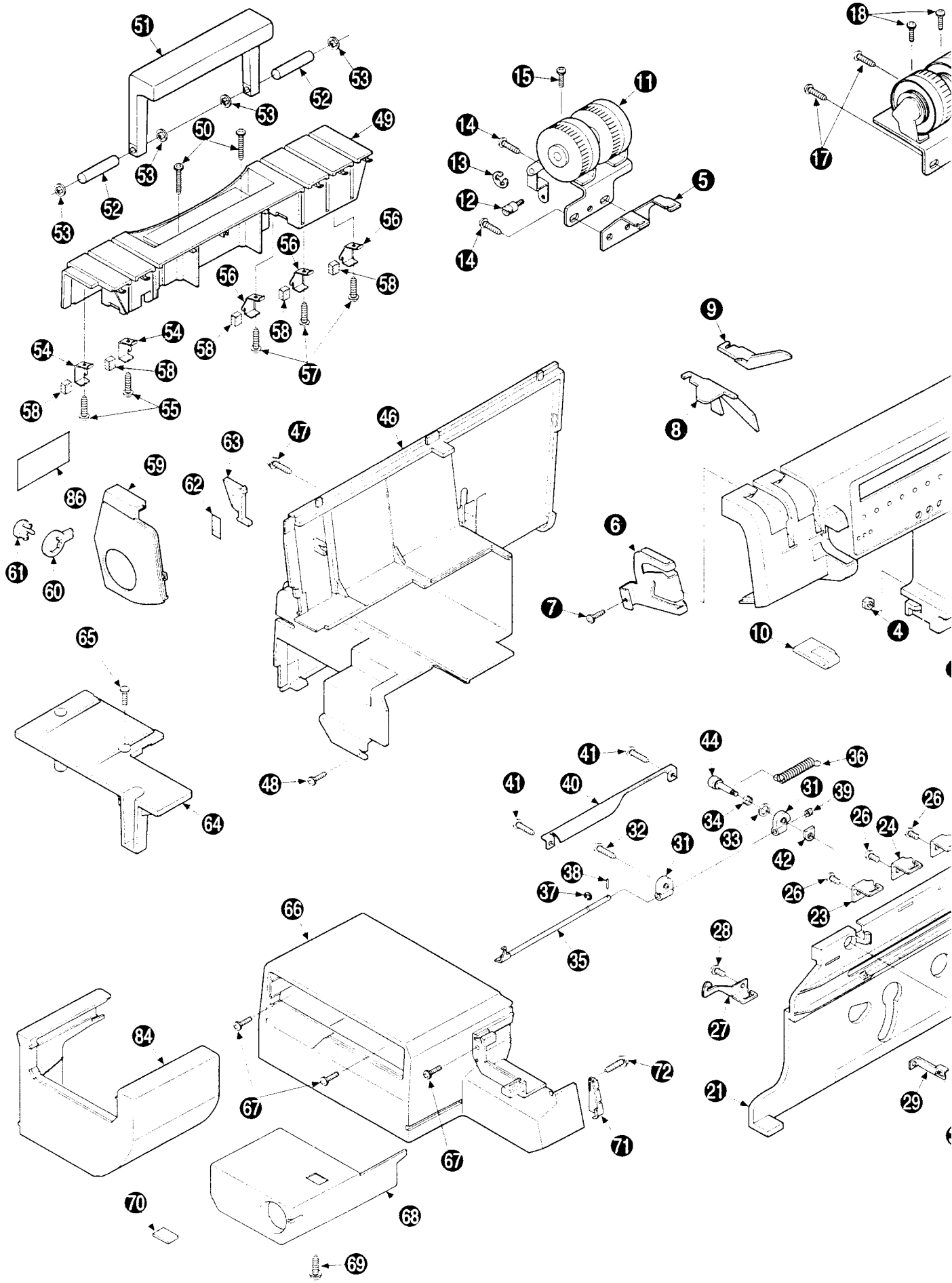

No.	Part No.	Description	Qt.
1	ML351711	Front cover	1
2	ML106241	Front cover screw	1
3	ML106242	Front cover screw	1
4	ML106084	Lower cover nut	2
5	ML350701	Needle thread guide (A)	1
6	ML350702	Needle bar drive link thread take-up cover	1
7	ML106242	Needle bar drive link thread take-up cover screw	1
8	ML350703	Needle thread guide (B)	1
9	ML350704	Needle thread guide (C)	1
10	ML350786	Needle thread guard (B)	1
11	ML351720	Needle thread regulator (complete)	1
12	ML350714	Thread tension disengagement link pin	1
13	ML106140	Thread tension disengagement link pin ring	1
14	ML106315	Needle thread regulator (complete) screw	2
15	ML106208	Needle thread regulator (complete) screw	1
16	ML351721	Looper thread regulator (complete)	1
17	ML106315	Looper thread regulator (complete) screw	2
18	ML106208	Looper thread regulator (complete) screw	2
19	ML351719	Front cover thread guide	1
20	ML351713	LCD cover panel	1
21	ML350724	Lower cover	1
22	ML106242	Lower cover screw	2
23	ML350725	Looper thread guide (red)	1
24	ML350726	Looper thread guide (yellow)	1
25	ML350727	Looper thread guide (mauve)	1
26	ML106136	Looper thread guide screw	3

No.	Part No.	Description	Qt.
27	ML350728	Right looper thread guide	1
28	ML106136	Right looper thread guide screw	1
29	ML350729	Lower cover thread guide	1
30	ML106253	Lower cover thread guide screw	1
31	ML350730	Universal joint (complete)	2
32	ML106320	Universal joint screw	1
33	ML106091	Universal joint washer	1
34	ML350733	Universal joint spring	1
35	ML350734	Left looper threader (complete)	1
36	ML350735	Left looper threader spring	1
37	ML106257	Left looper threader ring	1
38	ML350736	Guide pin	1
39	ML350737	Guide spring	1
40	ML350738	Guide	1
41	ML106136	Guide screw	2
42	ML350739	Spacer	1
43	ML350740	Operation knob	1
44	ML106313	Operation knob screw	1
45	ML351715	Pulley cover	1
46	ML350742	Rear cover (complete)	1
	ML106084	Side cover nut	(2)
47	ML106317	Rear cover screw (rear)	1
48	ML106242	Rear cover screw (side)	1
49	ML350743	Handle bracket	1
50	ML106241	Handle bracket screw	2
51	ML350744	Handle	1
52	ML350745	Handle stop pin	1
53	ML106263	Handle stop pin ring	4
54	ML350746	Rear needle thread guide	2
55	ML106136	Rear needle thread guide screw	2
56	ML350747	Rear looper thread guide	3
57	ML106136	Rear looper thread guide screw	3
58	ML350748	Sponge	5
59	ML351717	Lamp cover	1
60	ML350750	Lamp cover fixing plate	1
61	ML350751	Lamp cover fixing lever	1
62	ML342720	Thread chain cutter	1
63	ML342721	Thread chain cutter guide	1
64	ML350752	Transform cover	1
65	ML106243	Transform cover screw	1
66	ML350753	Side cover (complete)	1
	ML106084	Free arm cover nut	(1)
67	ML106242	Side cover screw	3
68	ML351718	Free arm cover	1
69	ML106242	Free arm cover screw	1
70	ML350755	Transparent cover plate (S)	1
71	ML350756	Upper knife lever cover	1
72	ML106322	Upper knife lever cover screw	1
73	ML350757	Looper cover	1
74	ML350758	Looper cover hinge	1
75	ML350759	Looper cover hinge pin	1
76	ML106139	Looper cover hinge pin ring	1
77	ML350785	Looper cover sliding spring	1
78	ML350760	Switching operation dog	1
79	ML350761	Switching operation dog spring	1
80	ML106314	Looper cover screw	2
81	ML350762	Chip cover	1
82	ML350763	Chip cover spring plate	2
83	ML106136	Chip cover spring plate screw	2
84	ML350921	Flat table (complete)	1
85	ML351747	Threading mark	1
86	ML351749	Rating plate	1
87	ML350769	Sewing pattern mark	1

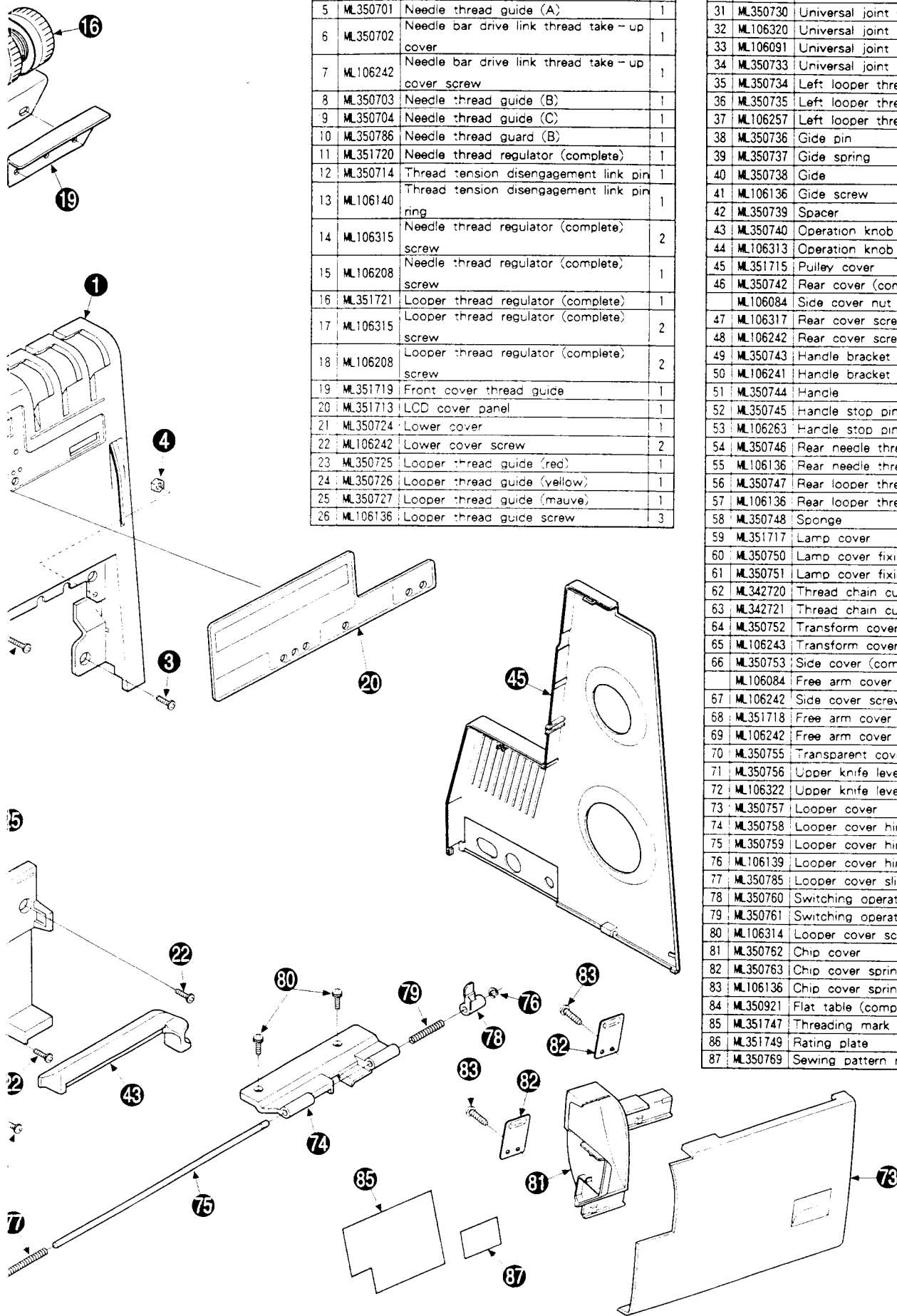

L. ACCESSORIES

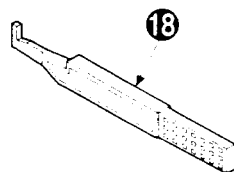
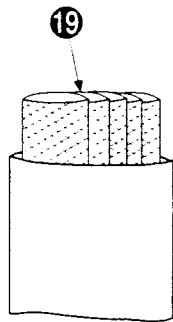
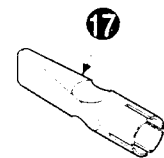
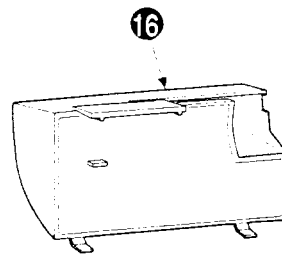
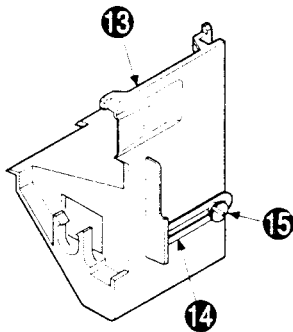
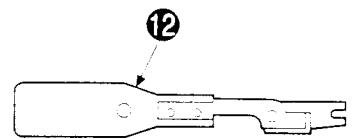
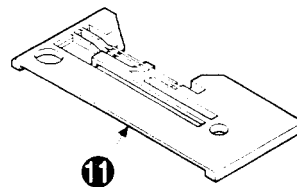
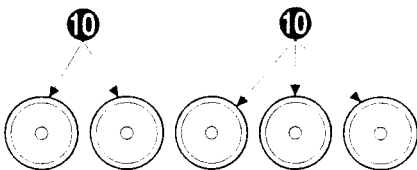
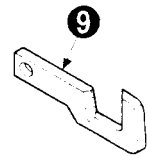
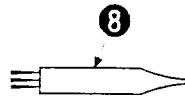
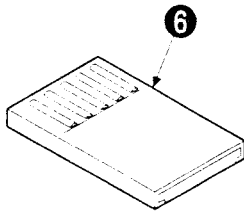
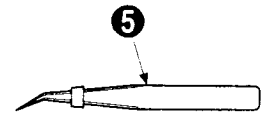
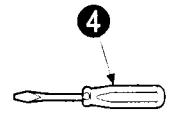
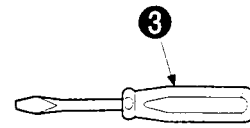
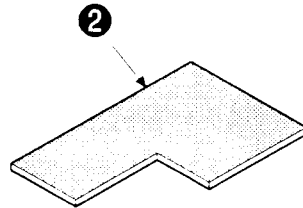
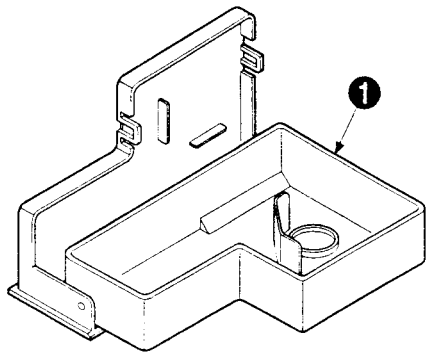

No.	Part No.	Description	Qt.
1	ML350924	Accessory box (complete)	1
2	ML350911	Sponge	1
3	ML330903	Screw driver (big)	1
4	ML330918	Screw driver (small)	1
5	ML341909	Tweezers	1
6	ML350214	Needle (complete) Cat. No. 2022	1
7	ML330906	Oiler	1
8	ML330905	Brush	1
9	ML350414	Upper knife	1
10	ML320931	Thread stripping discs	5
11	ML350361	Needle plate (complete) (for rolled hem)	1
12	ML340970	Needle threader	1
13	ML350903	Guide plate	1
14	ML350913	Welt guide	1
15	ML106096	Welt guide screw	1
16	ML350918	Crip box (complete)	1
17	ML350907	Lamp remover (complete)	1
18	ML350915	Needle inserter	1
19	ML330915	Thread spool net	5
20	ML350926	Dust cover	1

