

ILLUSTRATED PARTS LIST

SINGER®

MACHINE

14U 544
554
555
557

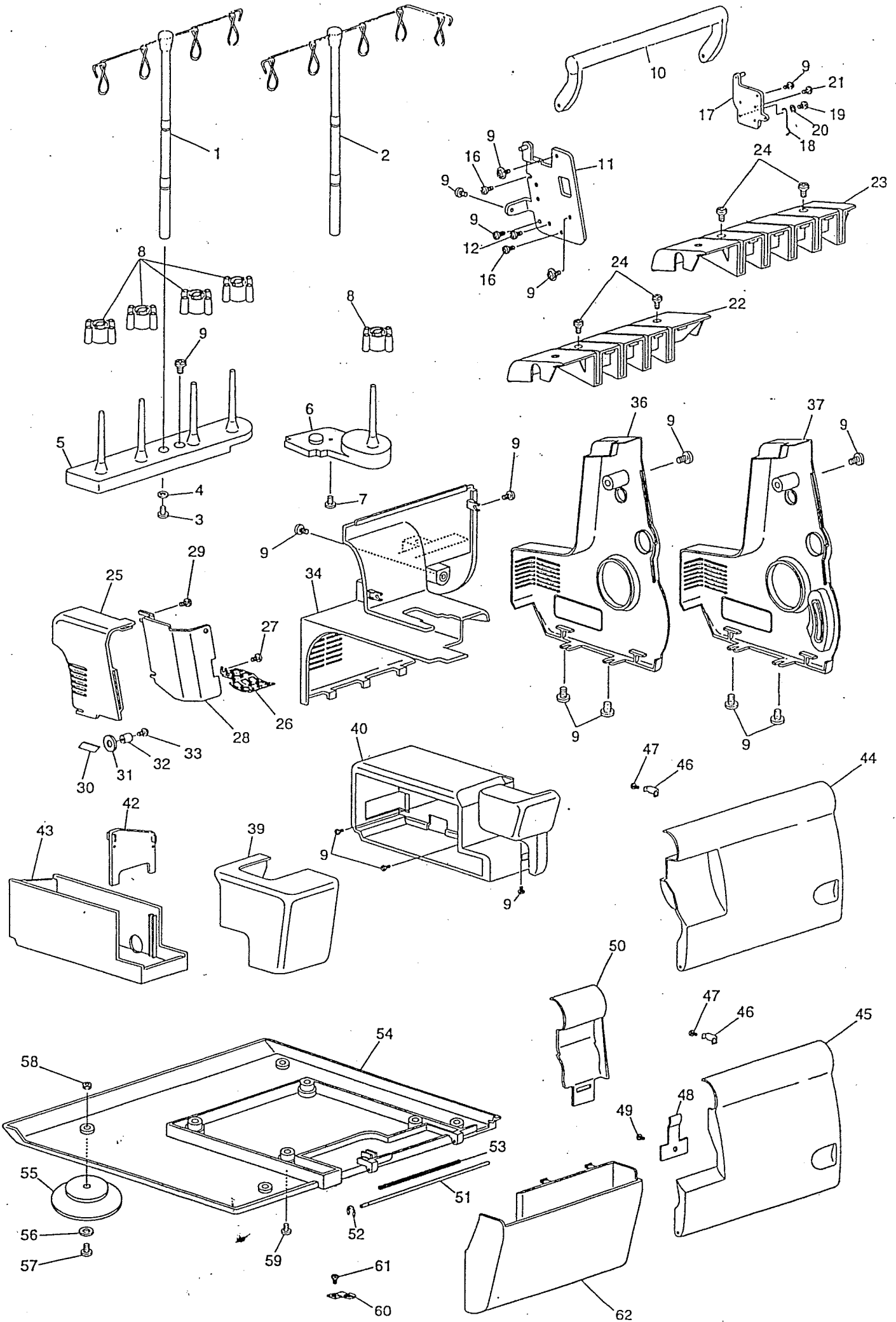

NO.	PART NO.	544	554	555	557	QTY.	DESCRIPTION
1	550346	*	*	-	-	1	THREAD UNWINDER THREAD GUIDE ROD COMP. (FOR 4 THREAD)
2	550349	-	-	*	*	1	THREAD UNWINDER THREAD GUIDE ROD COMP. (FOR 5 THREAD)
3	544212-003	*	*	*	*	1	THREAD UNWINDER THREAD GUIDE ROD SCREW
4	543805-003	*	*	*	*	1	THREAD UNWINDER THREAD GUIDE ROD SCREW WASHER
5	550345-391	*	*	*	*	1	THREAD UNWINDER (FOR 4 THREAD)
6	550348-391	-	-	*	*	1	THREAD UNWINDER (FOR 5 THREAD)
7	412697-002	-	-	*	*	1	THREAD UNWINDER (FOR 5 THREAD) SCREW
8	546893	*	*	-	-	4	SPOOL HOLDER
8	546893	-	-	*	*	5	SPOOL HOLDER
9	544270-001	*	*	*	*	14	SCREW
10	550310-391	*	*	*	*	1	HANDLE
11	550314	*	*	*	*	1	HANDLE BRACKET (LEFT) COMP.
12	544211-002	*	*	*	*	1	PRESSER BAR OIL FELT SCREW
16	544212-001	*	*	*	*	2	HANDLE BRACKET (LEFT) COMP. SCREW
17	550311	*	*	*	*	1	HANDLE BRACKET (RIGHT) COMP.
18	550391	*	*	*	*	1	PRESSER BAR LIFTER LEVER SPRING
19	544212-001	*	*	*	*	1	PRESSER BAR LIFTER LEVER SPRING SCREW
20	543803-003	*	*	*	*	1	PRESSER BAR LIFTER LEVER SPRING SCREW WASHER
21	544212-001	*	*	*	*	1	HANDLE BRACKET (RIGHT) COMP. SCREW
22	550306-391	*	*	-	-	1	TOP COVER COMP. (FOR 4 THREAD)
23	550309-391	-	-	*	*	1	TOP COVER COMP. (FOR 5 THREAD)
24	544212-072	*	*	*	*	2	TOP COVER SCREW
25	550331-391	*	*	*	*	1	LIGHT COVER
26	550332	*	*	*	*	1	LIGHT GRILLE
27	412697-002	*	*	*	*	1	LIGHT GRILLE SCREW
28	550333	*	*	*	*	1	LIGHT SHIELD
29	412697-002	*	*	*	*	1	LIGHT SHIELD SCREW
30	550334	*	*	*	*	1	THREAD CUTTER
31	543803-005	*	*	*	*	1	THREAD CUTTER WASHER
32	543877-007	*	*	*	*	1	THREAD CUTTER SPEACER
33	543878-001	*	*	*	*	1	THREAD CUTTER SCREW
34	550476-391	*	*	*	*	1	REAR COVER
36	550336-391	*	-	-	-	1	PULLEY COVER
37	550337-391	-	*	*	*	1	PULLEY COVER (FOR DIFFERENTIAL FEED)
39	550338-391	*	*	*	*	1	CLOTH PLATE (FRONT) COMP.
40	550341-391	*	*	*	*	1	CLOTH PLATE (BACK)
42	550342-391	*	*	*	*	1	ACCESSORY CASE PARTITION PLATE
43	550343-391	*	*	*	*	1	ACCESSORY CASE (LOWER)
44	550317-401	*	-	-	-	1	LOOPER COVER (GRAPHIC) (FOR 544) (ULTRALOCK)
44	550317-402	-	*	-	-	1	LOOPER COVER (GRAPHIC) (FOR 554) (ULTRALOCK)
44	550317-405	*	-	-	-	1	LOOPER COVER (GRAPHIC) (FOR 544) (MILLENNIUM SERIES)
44	550317-406	-	*	-	-	1	LOOPER COVER (GRAPHIC) (FOR 554) (MILLENNIUM SERIES)
45	550603-401	-	-	*	-	1	LOOPER COVER (BODY) COMP. (FOR 555) (ULTRALOCK)
45	550603-402	-	-	*	-	1	LOOPER COVER (BODY) COMP. (FOR 555) (MILLENNIUM SERIES)
45	550603-403	-	-	*	-	1	LOOPER COVER (BODY) COMP. (FOR 557) (MILLENNIUM SERIES)
46	281472	*	*	*	*	1	LOOPER COVER HOOK
47	544248-003	*	*	*	*	1	LOOPER COVER HOOK SCREW
48	550426	-	-	*	*	1	CHIP GUARD PRESSER SPRING
49	412697-002	-	-	*	*	1	CHIP GUARD PRESSER SPRING SCREW
50	550326-391	-	-	*	*	1	CHIP GUARD (FOR 5 THREAD)
51	550327	*	*	*	*	1	LOOPER COVER HINGE PIN
52	543801-002	*	*	*	*	1	LOOPER COVER HINGE PIN RETAINING RING
53	550328	*	*	*	*	1	LOOPER COVER HINGE PIN SPRING
54	550303-391	*	*	*	*	1	MACHINE BASE
55	410208	*	*	*	*	4	MACHINE BASE CUSHION
56	543803-004	*	*	*	*	4	MACHINE BASE CUSHION SCREW WASHER
57	544218-003	*	*	*	*	4	MACHINE BASE CUSHION SCREW
58	541166-001	*	*	*	*	4	MACHINE BASE CUSHION SCREW NUT
59	544213-005	*	*	*	*	4	MACHINE BASE SCREW
60	550772	-	-	*	*	1	CHAIN STITCH LOOPER THREAD GUIDE (SMALL)
61	544248-002	-	-	*	*	1	CHAIN STITCH LOOPER THREAD GUIDE (SMALL) SCREW
62	550608-401	*	-	-	-	1	CLEAN POCKET (GRAPHIC) (FOR 544) (ULTRALOCK)
62	550608-402	-	*	*	-	1	CLEAN POCKET (GRAPHIC) (FOR 554/555) (ULTRALOCK)
62	550608-405	*	-	-	-	1	CLEAN POCKET (GRAPHIC) (FOR 544) (MILLENNIUM SERIES)
62	550608-406	-	*	*	-	1	CLEAN POCKET (GRAPHIC) (FOR 554/555) (MILLENNIUM SERIES)
62	550608-407	-	-	*	*	1	CLEAN POCKET (GRAPHIC) (FOR 557) (MILLENNIUM SERIES)

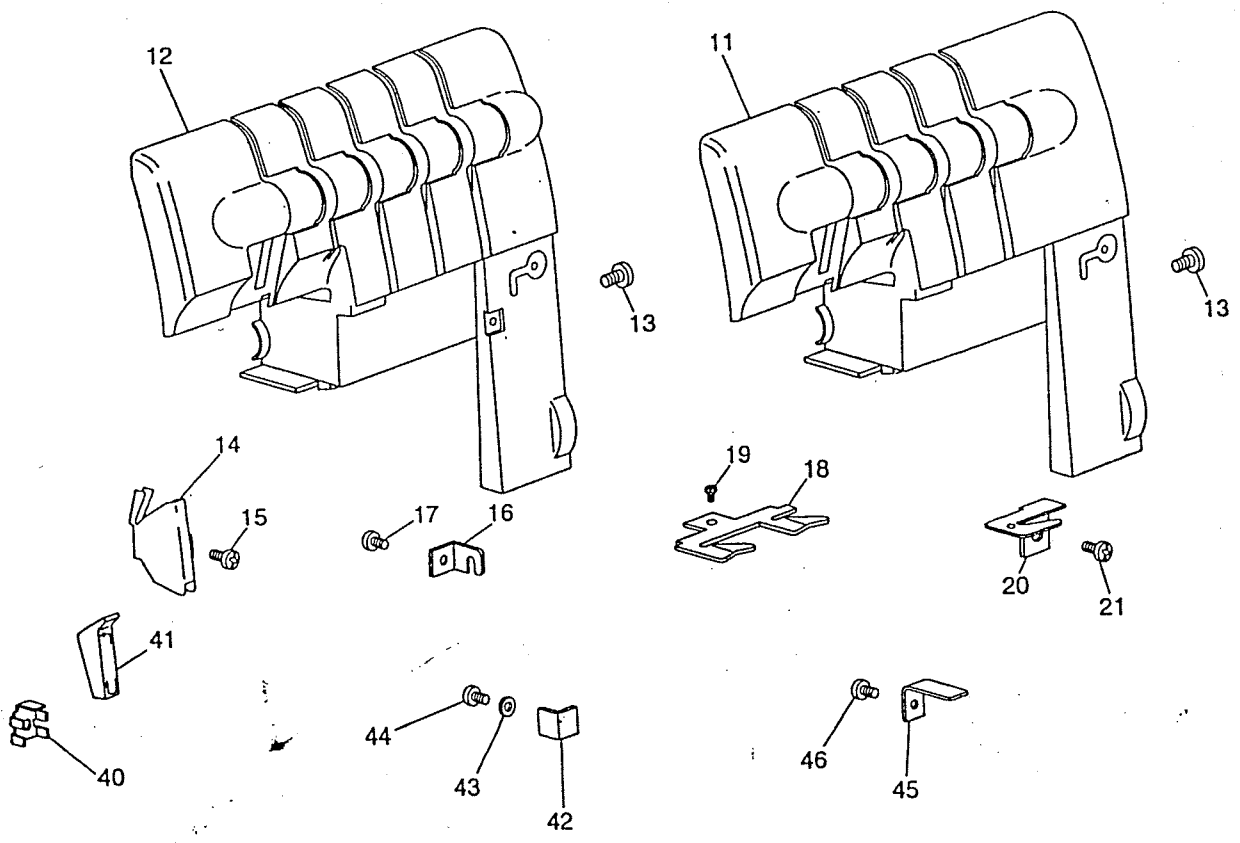
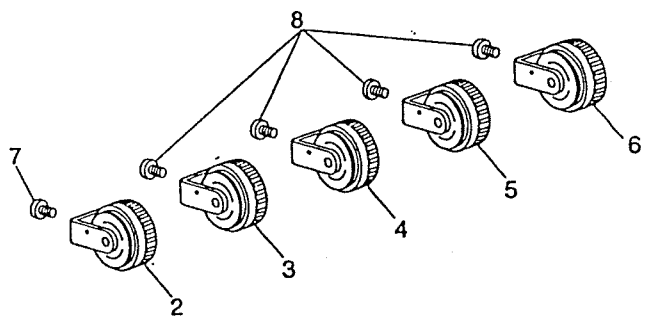
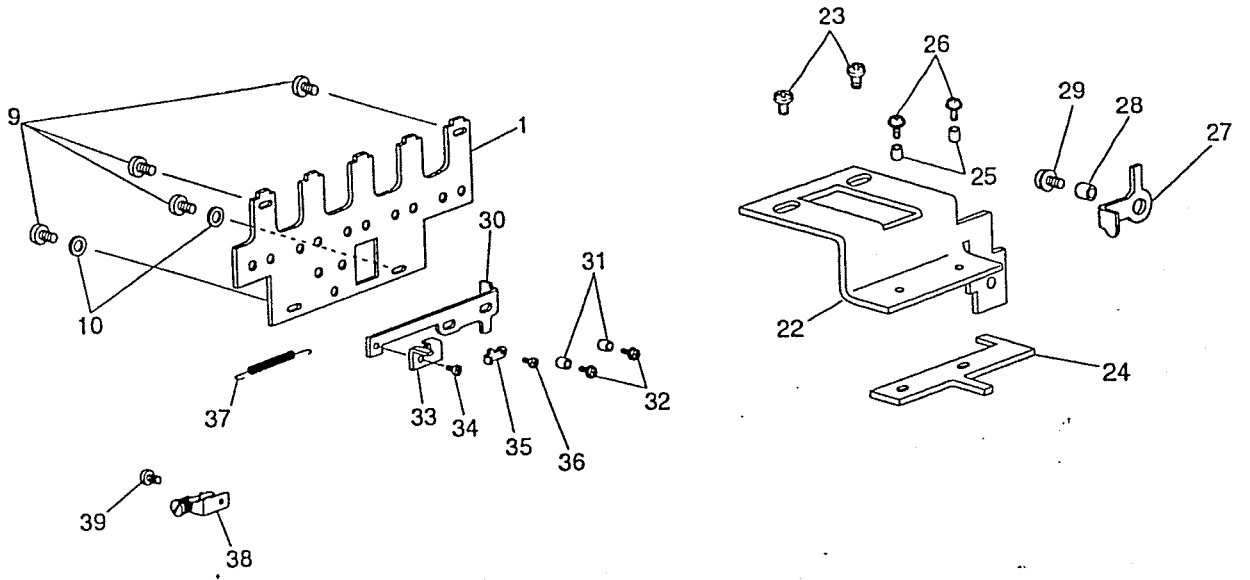

NO.	PART NO.	544	554	555	557	QTY.	DESCRIPTION
1	550773	*	*	*	*	1	TENSION DIAL BRACKET
2	550355-381	*	*	*	*	1	ONE TURN TENSION DIAL COMP. (LEFT NEEDLE THREAD)
3	550361-381	*	*	*	*	1	ONE TURN TENSION DIAL COMP. (RIGHT NEEDLE THREAD)
4	550362-381	*	*	*	*	1	ONE TURN TENSION DIAL COMP. (RIGHT LOOPER THREAD)
5	550363-381	*	*	*	*	1	ONE TURN TENSION DIAL COMP. (LEFT LOOPER THREAD)
6	550368-381	-	-	-	-	1	ONE TURN TENSION DIAL COMP. (CHAIN LOOPER THREAD)
7	544265	*	*	*	*	1	ONE TURN TENSION DIAL COMP. (CHAIN LOOPER THREAD)
8	544212-006	*	*	-	-	3	ONE TURN TENSION DIAL COMP. SCREW
8	544212-006	-	-	*	*	4	ONE TURN TENSION DIAL COMP. SCREW
9	412697-002	*	*	*	*	4	ONE TURN TENSION DIAL COMP. SCREW
10	543804-003	*	*	*	*	2	ONE TURN TENSION DIAL COMP. SET SCREW
11	550604-401	*	*	-	-	1	FRONT COVER (BODY) COMP. (FOR 4 THREAD)
12	550605-401	-	-	*	-	1	FRONT COVER (BODY) COMP. (FOR 5 THREAD)
12	556039-401	-	-	-	*	1	FRONT COVER (BODY) COMP. (FOR 5 THREAD)
13	544270-001	*	*	*	*	1	FRONT COVER SCREW
14	281487	*	*	-	-	1	FRONT COVER THREAD GUIDE (FOR 4 THREAD)
14	550366	-	-	*	-	1	FRONT COVER THREAD GUIDE (FOR 5 THREAD)
14	550775	-	-	-	*	1	FRONT COVER THREAD GUIDE (FOR 5 THREAD)
15	412697	*	*	*	*	1	FRONT COVER THREAD GUIDE BRACKET SCREW
16	412531	*	*	*	*	1	FRONT COVER THREAD GUIDE (SMALL)
17	412697-003	*	*	*	*	1	FRONT COVER THREAD GUIDE (SMALL) SCREW
18	550352	*	*	*	*	1	FRONT COVER THREAD GUIDE (LOWER)
19	544211-002	*	*	*	*	1	FRONT COVER THREAD GUIDE (LOWER) SCREW
20	550369	-	-	*	-	1	CHAIN STITCH LOOPER THREAD GUIDE
21	412697-003	-	-	*	-	1	CHAIN STITCH LOOPER THREAD GUIDE SCREW
22	550790	-	-	-	*	1	TENSION RELEASE BRACKET
23	544212-001	-	-	-	*	2	TENSION RELEASE BRACKET SET SCREW
24	550791	-	-	-	*	1	TENSION RELEASE ACTUATING PLATE
25	543876-002	-	-	-	*	2	TENSION RELEASE ACTUATING PLATE SPECER
26	544270-003	-	-	-	*	2	TENSION RELEASE ACTUATING PLATE SCREW
27	550792	-	-	-	*	1	TENSION RELEASE LEVER
28	543876-002	-	-	-	*	1	TENSION RELEASE LEVER SPECER
29	544270-003	-	-	-	*	1	TENSION RELEASE LEVER SCREW
30	550786	-	-	-	*	1	TENSION RELEASE PLATE
31	543876-002	-	-	-	*	2	TENSION RELEASE PLATE SPECER
32	544270-003	-	-	-	*	2	TENSION RELEASE PLATE SCREW
33	550787	-	-	-	*	1	TENSION RELEASE AUXILIARY PLATE
34	544212-006	-	-	-	*	1	TENSION RELEASE AUXILIARY PLATE SCREW
35	556055	-	-	-	*	1	TENSION RELEASE PLATE STOP PLATE
36	544212-001	-	-	-	*	1	TENSION RELEASE PLATE STOP PLATE SCREW
37	550788	-	-	-	*	1	TENSION RELEASE PLATE SPRING
38	550779	-	-	-	*	1	THREAD CONTROLLER GUIDE SPRING COMP.
39	412697-003	-	-	-	*	1	THREAD CONTROLLER GUIDE SPRING COMP. SCREW
40	550776	-	-	-	*	1	NEEDLE THREAD GUIDE SUPPORT PLATE
41	550777-391	-	-	-	*	1	NEEDLE THREAD GUIDE
42	556037-391	-	-	-	*	1	FRONT COVER AUXILIARY PLATE
43	543804-002	-	-	-	*	1	FRONT COVER AUXILIARY PLATE SCREW WASHER
44	544248	-	-	-	*	1	FRONT COVER AUXILIARY PLATE SCREW
45	550778	-	-	-	*	1	CHAIN STITCH LOOPER THREAD GUIDE PLATE (FOR FRONT COVER)
46	544248-003	-	-	*	*	1	CHAIN STITCH LOOPER THREAD GUIDE PLATE (FOR FRONT COVER) SCREW

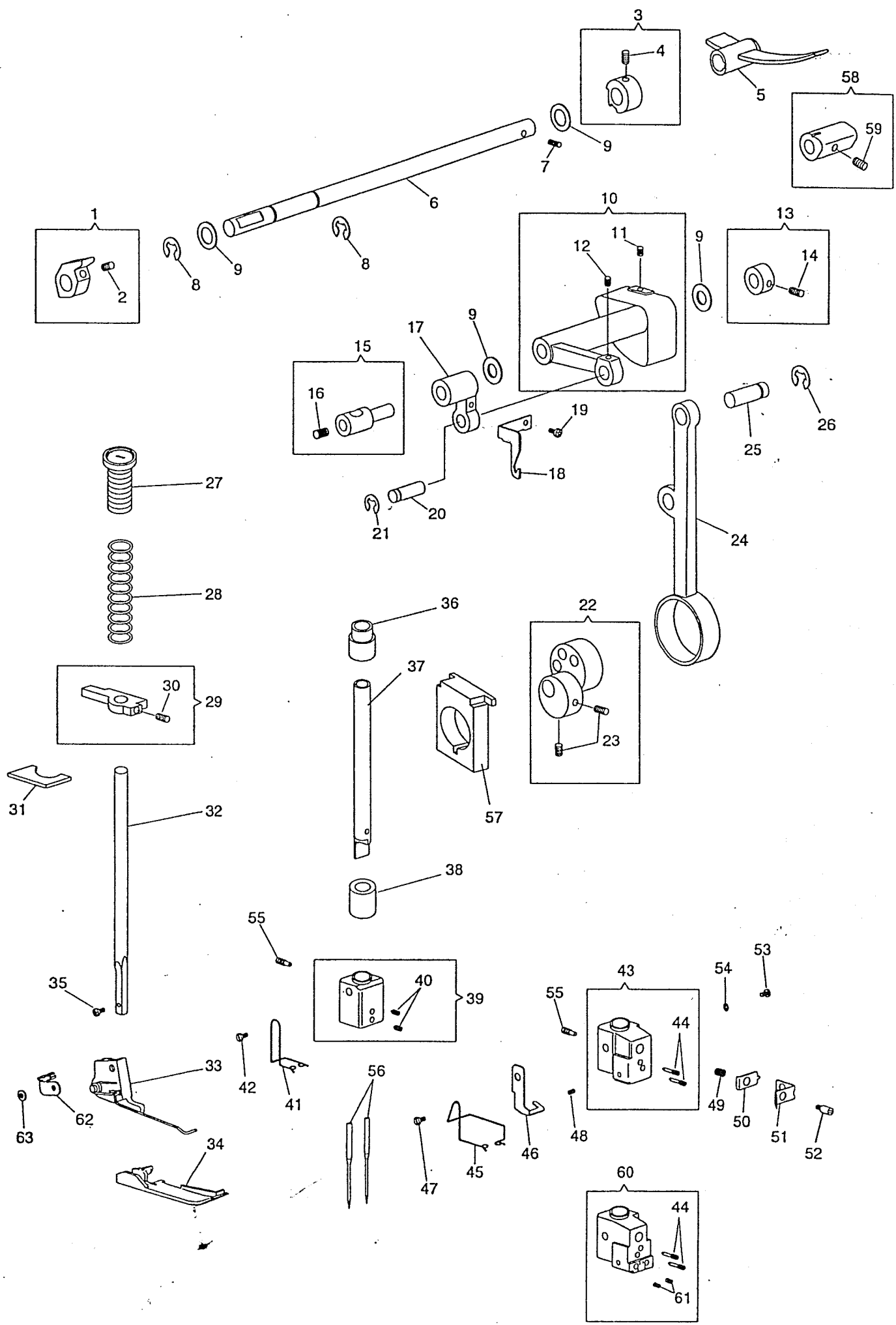

NO.	PART NO.	544	554	555	557	QTY.	DESCRIPTION
1	550386	*	*	*	*	1	PRESSER BAR LIFTER CAM (LEFT) COMP.
2	544207-011	*	*	*	*	1	PRESSER BAR LIFTER CAM (LEFT) SCREW
3	550388	*	*	*	*	1	PRESSER BAR LIFTER CAM (RIGHT) COMP.
4	544207-011	*	*	*	*	1	PRESSER BAR LIFTER CAM (RIGHT) SCREW
5	550390-381	*	*	*	*	1	PRESSER BAR LIFTER LEVER
6	550392	*	*	*	*	1	ARM SHAFT
7	544207-012	*	*	*	*	1	PRESSER BAR LIFTER LEVER SCREW
8	543801-007	*	*	*	*	2	ARM SHAFT RETAINING RING
9	542402	*	*	*	*	4	ARM SHAFT THRUST WASHER
10	550404	*	*	*	*	1	NEEDLE BAR CRANK COMP.
11	544207-011	*	*	*	*	1	NEEDLE BAR CRANK ROD PIN SCREW
12	544207-011	*	*	*	*	1	NEEDLE BAR CONNECTING LINK PIN SCREW
13	550393	*	*	*	-	1	ARM SHAFT COLLAR COMP.
14	544207-011	*	*	*	-	1	ARM SHAFT COLLAR SCREW
15	410325	*	*	*	*	1	NEEDLE BAR CONNECTING STUD COMP.
16	544044	*	*	*	*	1	NEEDLE BAR CONNECTING STUD SCREW
17	410327	*	*	*	*	1	NEEDLE BAR CONNECTING LINK
18	281488	*	*	-	-	1	STRIKER (FOR 4 THREAD)
18	550401	-	-	*	*	1	STRIKER (FOR 5 THREAD)
19	544211-051	*	*	*	*	1	STRIKER SCREW
20	370270-900	*	*	*	*	1	NEEDLE BAR CONNECTING LINK PIN
21	543801-006	*	*	*	*	1	NEEDLE BAR CONNECTING LINK PIN RETAINING RING
22	550402	*	*	*	*	1	NEEDLE BAR ECCENTRIC CAM COMP.
23	544207-011	*	*	*	*	2	NEEDLE BAR ECCENTRIC CAM SET SCREW
24	376804-900	*	*	*	*	1	NEEDLE BAR CRANK ROD
25	370270-900	*	*	*	*	1	NEEDLE BAR CONNECTING LINK PIN
26	543801-006	*	*	*	*	1	NEEDLE BAR CONNECTING LINK PIN RETAINING RING
27	550370-391	*	*	*	*	1	PRESSER REGULATING THUMB SCREW COMP.
28	550372	*	*	*	*	1	PRESSER BAR SPRING
29	550373	*	*	*	*	1	PRESSER BAR GUIDE BRACKET COMP.
30	544207-011	*	*	*	*	1	PRESSER BAR GUIDE BRACKET SCREW
31	550304	*	*	*	*	1	PRESSER BAR OIL FELT
32	410351	*	*	*	*	1	PRESSER BAR
33	550379-452	*	*	*	*	1	PRESSER FOOT SHANK COMP.
34	550376-452	*	*	*	*	1	PRESSER FOOT COMP.
35	504063-451	*	*	*	*	1	PRESSER FOOT SCREW
36	410323	*	*	*	*	1	NEEDLE BAR BUSHING (UPPER)
37	550395	*	*	*	*	1	NEEDLE BAR
38	410324	*	*	*	*	1	NEEDLE BAR BUSHING (LOWER)
39	550590	*	*	-	-	1	NEEDLE CLAMP (BODY) COMP. (FOR 4 THREAD)
40	374617	*	*	-	-	2	NEEDLE SET SCREW
41	376848	*	*	-	-	1	NEEDLE CLAMP THREAD GUIDE
42	544211-059	*	*	-	-	1	NEEDLE CLAMP THREAD GUIDE SET SCREW
43	550398	-	-	*	*	1	NEEDLE CLAMP (BODY) COMP. (FOR 5 THREAD)
44	374365	-	-	*	*	2	NEEDLE SCREW (OVEREDGE NEEDLE)
45	550558	-	-	*	-	1	NEEDLE CLAMP THREAD GUIDE
45	550799	-	-	*	-	1	NEEDLE CLAMP THREAD GUIDE
46	550559	-	-	*	-	1	OVEREDGE NEEDLE THREAD GUIDE
46	550800	-	-	*	-	1	OVEREDGE NEEDLE THREAD GUIDE
47	374353	-	-	*	*	1	NEEDLE CLAMP THREAD GUIDE SET SCREW
48	544202-454	-	-	*	-	1	NEEDLE SCREW (CHAIN STITCH NEEDLE)
49	370233	-	-	*	*	1	NEEDLE THREAD PRE-TENSION SPRING
50	370231	-	-	*	*	1	NEEDLE THREAD PRE-TENSION PLATE
51	376637	-	-	*	*	1	NEEDLE THREAD PRE-TENSION BRACKET
52	374352	-	-	*	*	1	NEEDLE THREAD PRE-TENSION PLATE STUD SCREW
53	374353	-	-	*	*	1	NEEDLE THREAD PRE-TENSION BRACKET SCREW
54	543804-002	-	-	*	*	1	NEEDLE THREAD PRE-TENSION BRACKET SCREW WASHER
55	374102	*	*	*	*	1	NEEDLE CLAMP (BODY) SCREW
56	N2054-42-14	*	*	*	*	2	NEEDLE(#14)
57	550635	*	*	*	*	1	KNIFE (MOVABLE) FORKED LEVER SLIDE BLOCK
58	550794	-	-	*	*	1	TENSION RELEASE CAM COMP.
59	544207-011	-	-	*	*	1	TENSION RELEASE CAM SCREW
60	550797	-	-	*	*	1	NEEDLE CLAMP (BODY) COMP. (FOR 557)
61	374364	-	-	*	*	2	NEEDLE SCREW (COVER STITCH NEEDLE)
62	550793	-	-	*	*	1	SEAM GUIDE HOLDER
63	543804-009	-	-	*	*	1	PRESSER FOOT SCREW WASHER

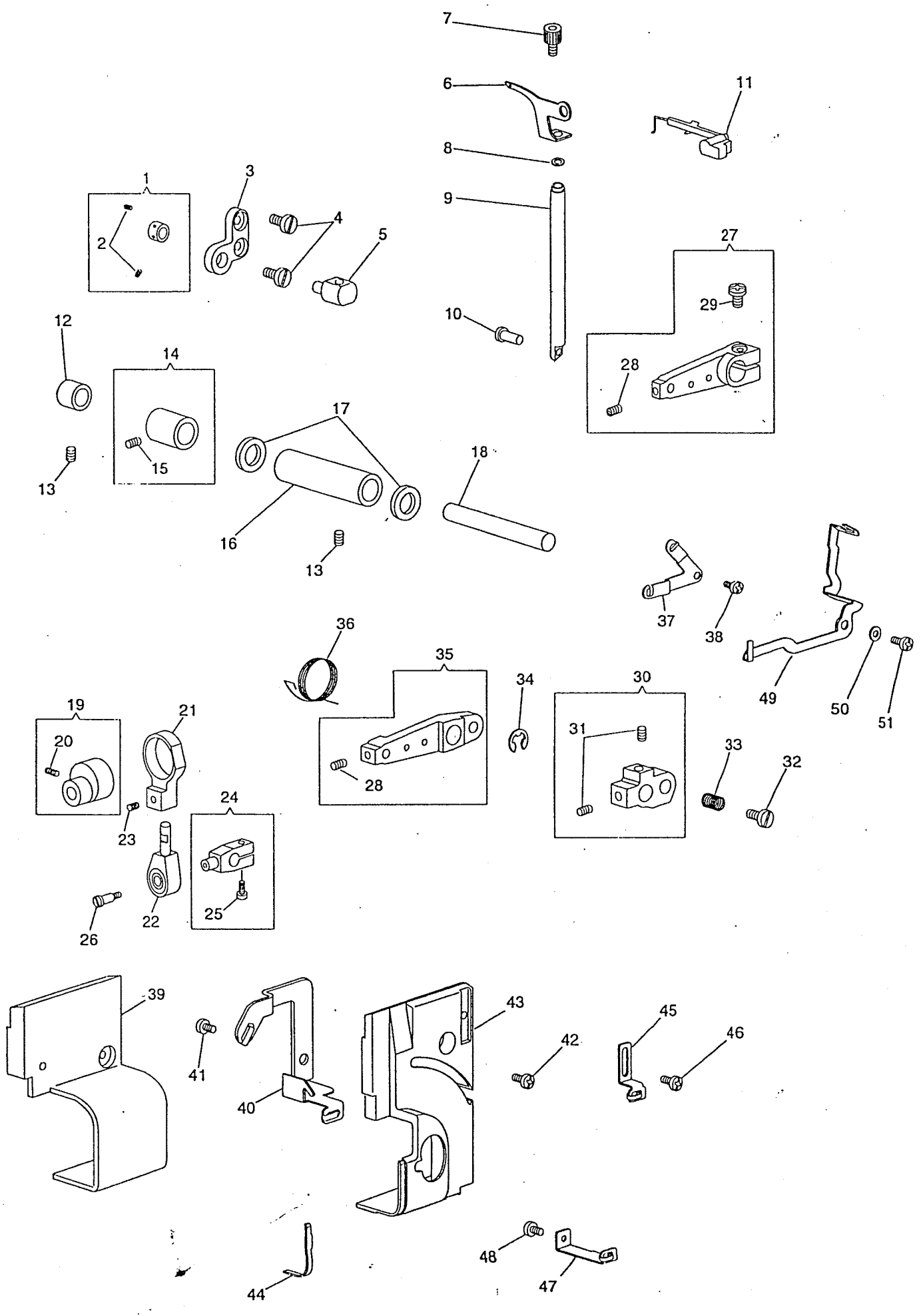

NO.	PART NO.	544	554	555	557	QTY.	DESCRIPTION
1	550396	*	*	*	*	1	RIGHT LOOPER RETAINER GUIDE COLLAR COMP
2	544207-011	*	*	*	*	2	RIGHT LOOPER RETAINER GUIDE COLLAR SCREW
3	370281	*	*	-	-	1	RIGHT LOOPER RETAINER GUIDE BRACKET
3	370272	-	-	*	*	1	RIGHT LOOPER REITANER GUIDE BRACKET
4	544213-002	*	*	*	*	2	RIGHT LOOPER RETAINER GUIDE BRACKET SCREW
5	410429	*	*	*	*	1	RIGHT LOOPER RETAINER GUIDE
6	550568	*	*	*	*	1	RIGHT LOOPER
7	414749-003	*	*	*	*	1	RIGHT LOOPER SCREW
8	543871-006	-	-	*	*	1	RIGHT LOOPER RETAINER O-RING
9	410435	*	*	*	*	1	RIGHT LOOPER RETAINER
10	370290	*	*	*	*	1	RIGHT LOOPER RETAINER DRIVING LEVER STUD
11	550547	*	*	*	*	1	SPREADER COMP.
12	550422	-	-	*	*	1	RIGHT LOOPER SHAFT BUSHING (BACK)
13	544207-011	*	*	-	-	1	RIGHT LOOPER SHAFT BUSHING SCREW
13	544207-011	-	-	*	*	2	RIGHT LOOPER SHAFT BUSHING SCREW
14	550393	-	-	*	*	1	RIGHT LOOPER SHAFT COLLAR COMP.
15	544207-011	-	-	*	*	1	RIGHT LOOPER SHAFT BUSHING SCREW
16	376799	*	*	-	-	1	RIGHT LOOPER SHAFT BUSHING
16	550421	-	-	*	*	1	RIGHT LOOPER SHAFT BUSHING (FRONT)
17	542402	*	*	*	*	2	RIGHT LOOPER SHAFT BUSHING THRUST WASHER
18	376813	*	*	-	-	1	RIGHT LOOPER SHAFT
18	550420	-	-	*	-	1	RIGHT LOOPER SHAFT
18	556009	-	-	-	*	1	RIGHT LOOPER SHAFT
19	550477	*	*	*	*	1	RIGHT LOOPER CAM COMP.
20	544207-011	*	*	*	*	2	RIGHT LOOPER CAM SCREW
21	412794	*	*	*	*	1	RIGHT LOOPER CAM ROD
22	412795	*	*	*	*	1	RIGHT LOOPER CAM ROD END
23	544208-002	*	*	*	*	1	RIGHT LOOPER CAM ROD END SET SCREW
24	412796	*	*	*	*	1	RIGHT LOOPER SHAFT LEVER COMP.
25	414750-001	*	*	*	*	1	RIGHT LOOPER SHAFT LEVER CLAMPING SCREW
26	374136	*	*	*	*	1	RIGHT LOOPER CAM ROD END SCREW STUD
27	550587	*	*	-	-	1	RIGHT LOOPER RETAINER DRIVING LEVER COMP.
28	544207-011	*	*	*	*	1	RIGHT LOOPER RETAINER DRIVING LEVER STUD SCREW
29	544213-053	*	*	-	-	1	RIGHT LOOPER RETAINER DRIVING LEVER CLAMPING SCREW
30	550596	-	-	*	*	1	RIGHT LOOPER RETAINER DRIVING LEVER (FRONT) COMP.
31	544208-005	-	-	*	*	2	RIGHT LOOPER RETAINER DRIVING LEVER (FRONT) SCREW
32	550313	-	-	*	*	1	RIGHT LOOPER RETAINER DRIVING LEVER LOCK SCREW
33	550418	-	-	*	*	1	RETURN SPRING
34	543801-003	-	-	*	*	1	RIGHT LOOPER RETAINER DRIVING LEVER LOCK SCREW
35	550597	-	-	*	*	1	RETAINING RING
36	550419	-	-	*	*	1	RIGHT LOOPER RETAINER DRIVING LEVER (BACK) COMP.
37	550406	*	*	*	*	1	RIGHT LOOPER RETAINER DRIVING LEVER (BACK) RETURN SPRING
38	544212-001	*	*	*	*	1	RIGHT LOOPER THREAD GUIDE
39	550606-401	*	*	-	-	1	RIGHT LOOPER THREAD GUIDE SCREW
39	550607-401	-	-	*	-	1	LOOPER THREAD GUIDE COVER (BODY) (COMP.) (FOR 4 THREAD)
40	550412	*	*	*	*	1	LOOPER THREAD GUIDE COVER (BODY) COMP. (FOR 5 THREAD)
41	412697-003	*	*	*	*	1	LOOPER THREAD GUIDE
42	544270-001	*	*	*	*	1	LOOPER THREAD GUIDE SCREW
43	556003-401	-	-	-	*	1	LOOPER THREAD GUIDE COVER SCREW
44	556005	-	-	-	*	1	LOOPER THREAD GUIDE COVER
45	556006	-	-	-	*	1	GUIDE PLATE FOR CHAIN STITCH LOOPER THREAD (FOR LOOPER THREAD GUIDE COVER)
46	544248-002	-	-	-	*	1	CHAIN STITCH LOOPER THREAD GUIDE (UPPER)
47	556007	-	-	-	*	1	CHAIN STITCH LOOPER THREAD GUIDE (UPPER) SCREW
48	412697-003	-	-	-	*	1	CHAIN STITCH LOOPER THREAD GUIDE (LOWER)
49	556010	-	-	-	*	1	CHAIN STITCH LOOPER THREAD GUIDE (LOWER) SCREW
50	543804-003	-	-	-	*	1	CHAIN STITCH LOOPER THREAD GUIDE (LARGE)
51	544212-001	-	-	-	*	1	CHAIN STITCH LOOPER THREAD GUIDE (LARGE) SCREW WASHER
							CHAIN STITCH LOOPER THREAD GUIDE (LARGE) SCREW

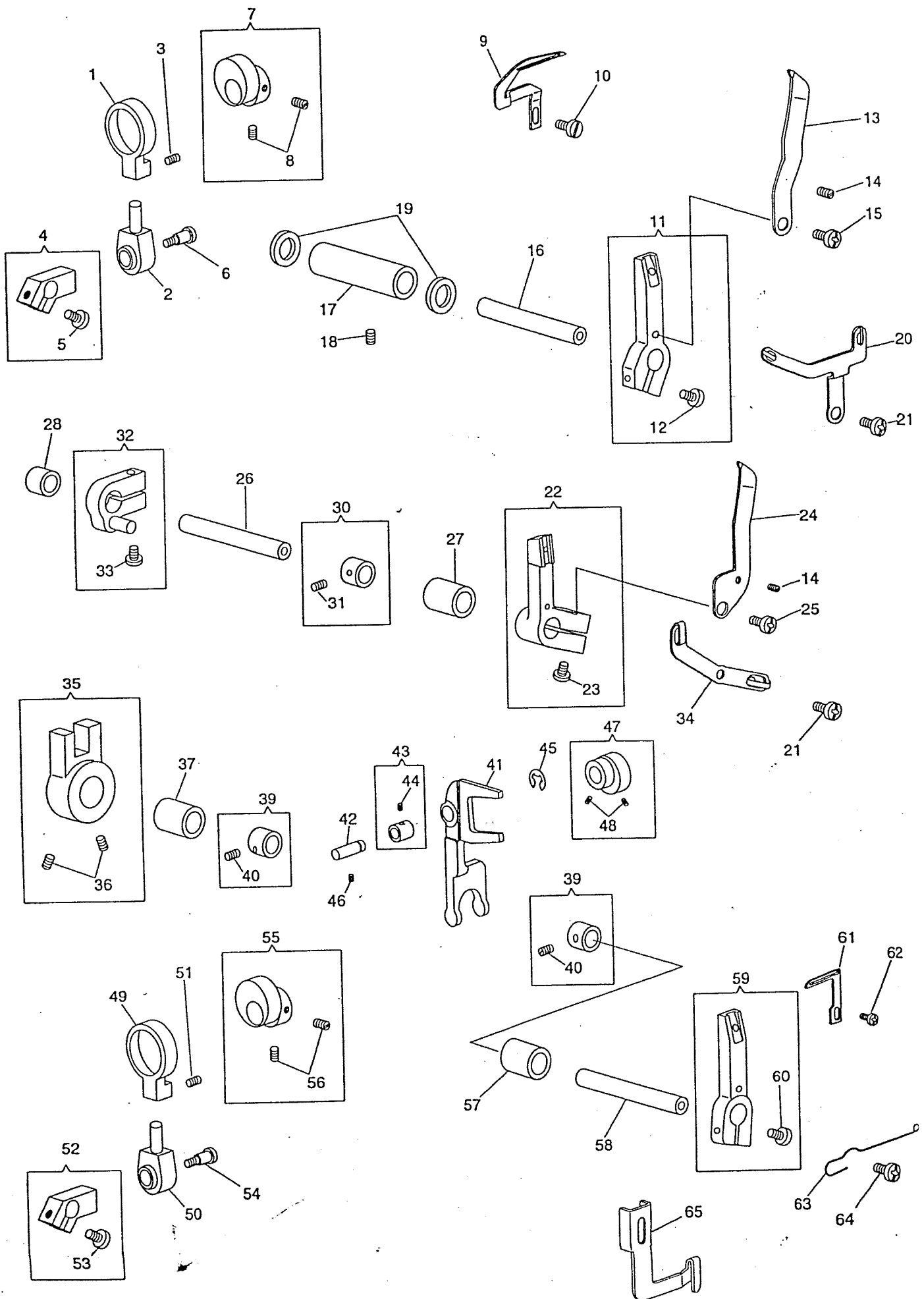

NO.	PART NO.	544	554	555	557	QTY.	DESCRIPTION
1	412794	*	*	*	*	1	LEFT LOOPER CAM ROD
2	412795	*	*	*	*	1	LEFT LOOPER CAM ROD END
3	544208-002	*	*	*	*	1	LEFT LOOPER CAM ROD END SET SCREW
4	412798	*	*	*	*	1	LEFT LOOPER SHAFT LEVER COMP.
5	414750-001	*	*	*	*	1	LEFT LOOPER SHAFT LEVER CLAMPING SCREW
6	374136	*	*	*	*	1	LEFT LOOPER CAM ROD END SCREW STUD
7	550477	*	*	*	*	1	LEFT LOOPER CAM COMP.
8	544207-011	*	*	*	*	2	LEFT LOOPER CAM SCREW
9	550411	*	*	*	*	1	LEFT LOOPER
10	544211-052	*	*	*	*	1	LEFT LOOPER SCREW
11	550409	*	*	*	*	1	LEFT LOOPER HOLDER COMP.
12	414750-001	*	*	*	*	1	LEFT LOOPER HOLDER CLAMPING SCREW
13	281481	*	*	*	*	1	NEEDLE GUARD (BACK) (FOR OVEREDGE NEEDLE)
14	374392	*	*	*	*	1	NEEDLE GUARD (BACK) (FOR OVEREDGE NEEDLE) ADJUSTING SCREW
15	544212-001	*	*	*	*	1	NEEDLE GUARD (BACK) (FOR OVEREDGE NEEDLE) SCREW
16	550407	*	*	*	*	1	LEFT LOOPER SHAFT
17	376798	*	*	*	*	1	LEFT LOOPER SHAFT BUSHING
18	544207-011	*	*	*	*	1	LEFT LOOPER SHAFT BUSHING SCREW
19	542402	*	*	*	*	2	LEFT LOOPER SHAFT BUSHING THRUST WASHER.
20	550410	*	*	*	*	1	LEFT LOOPER HOLDER THREAD GUIDE (FOR 4 THREAD)
21	544212-001	*	*	*	*	1	LEFT LOOPER HOLDER THREAD SCREW
22	550428	*	*	*	*	1	LEFT LOOPER HOLDER COMP.
23	414750-001	*	*	*	*	1	LEFT LOOPER HOLDER CLAMPING SCREW
24	376564	*	*	*	*	1	NEEDLE GUARD (BACK) (FOR OVEREDGE NEEDLE)
25	544258	*	*	*	*	1	NEEDLE GUARD (BACK) (FOR OVEREDGE NEEDLE) SCREW
26	376900	*	*	*	*	1	LEFT LOOPER SHAFT
27	410279	*	*	*	*	1	LEFT LOOPER SHAFT BUSHING (FRONT)
28	410280	*	*	*	*	1	LEFT LOOPER SHAFT BUSHING (BACK)
30	550393	*	*	*	*	1	LEFT LOOPER SHAFT COLLAR COMP.
31	544207-011	*	*	*	*	1	LEFT LOOPER SHAFT COLLAR SCREW
32	370203	*	*	*	*	1	LEFT LOOPER DRIVING ARM COMP.
33	544212-054	*	*	*	*	1	LEFT LOOPER DRIVING ARM SCREW
34	550429	*	*	*	*	1	LEFT LOOPER HOLDER THREAD GUIDE (FOR 5 THREAD)
35	370201	*	*	*	*	1	LEFT LOOPER DRIVING FORKED LEVER COMP.
36	544207-011	*	*	*	*	2	LEFT LOOPER DRIVING FORKED LEVER SCREW
37	550422	*	*	*	*	1	CHAIN STITCH LOOPER SHAFT BUSHING (BACK)
39	550393	*	*	*	*	2	CHAIN STITCH LOOPER SHAFT COLLAR COMP.
40	544207-011	*	*	*	*	2	CHAIN STITCH LOOPER SHAFT COLLAR SCREW
41	412565	*	*	*	*	1	CHAIN STITCH LOOPER AVOID CAM FORKED LEVER.
42	412566-900	*	*	*	*	1	CHAIN STITCH LOOPER AVOID CAM FORKED LEVER STUD
43	410409	*	*	*	*	1	CHAIN STITCH LOOPER AVOID CAM FORKED LEVER STUD COLLAR COMP.
44	504007	*	*	*	*	1	CHAIN STITCH LOOPER AVOID CAM FORKED LEVER STUD COLLAR SCREW
45	543801-006	*	*	*	*	1	CHAIN STITCH LOOPER AVOID CAM FORKED LEVER STUD RETAINING RING
46	544207-011	*	*	*	*	1	CHAIN STITCH LOOPER AVOID CAM FORKED LEVER STUD SCREW
47	550532	*	*	*	*	1	CHAIN STITCH LOOPER AVOID CAM COMP.
48	544206-011	*	*	*	*	2	CHAIN STITCH LOOPER AVOID CAM SCREW
49	412794	*	*	*	*	1	CHAIN STITCH LOOPER CAM ROD
50	412795	*	*	*	*	1	CHAIN STITCH LOOPER CAM ROD END
51	544208-002	*	*	*	*	1	CHAIN STITCH LOOPER CAM ROD END SCREW
52	376895	*	*	*	*	1	CHAIN STITCH LOOPER SHAFT LEVER COMP.
53	414750-001	*	*	*	*	1	CHAIN STITCH LOOPER SHAFT LEVER SCREW
54	374136	*	*	*	*	1	CHAIN STITCH LOOPER CAM ROD END SCREW STUD
55	550577	*	*	*	*	1	CHAIN STITCH LOOPER CAM COMP.
55	556014	*	*	*	*	1	CHAIN STITCH LOOPER CAM COMP.
56	544207-011	*	*	*	*	2	CHAIN STITCH LOOPER CAM SCREW
57	550421	*	*	*	*	1	CHAIN STITCH LOOPER SHAFT BUSHING (FRONT)
58	550425	*	*	*	*	1	CHAIN STITCH LOOPER SHAFT
59	412551	*	*	*	*	1	CHAIN STITCH LOOPER HOLDER COMP.
60	414750-001	*	*	*	*	1	CHAIN STITCH LOOPER HOLDER SCREW
61	570424	*	*	*	*	1	CHAIN STITCH LOOPER
61	556030	*	*	*	*	1	CHAIN STITCH LOOPER
62	549364	*	*	*	*	1	CHAIN STITCH LOOPER SCREW
63	412554	*	*	*	*	1	CHAIN STITCH LOOPER HOLDER THREAD GUIDE
64	544212-001	*	*	*	*	1	CHAIN STITCH LOOPER HOLDER THREAD GUIDE SCREW
65	556012	*	*	*	*	1	CHAIN STITCH LOOPER HOLDER THREAD GUIDE SCREW

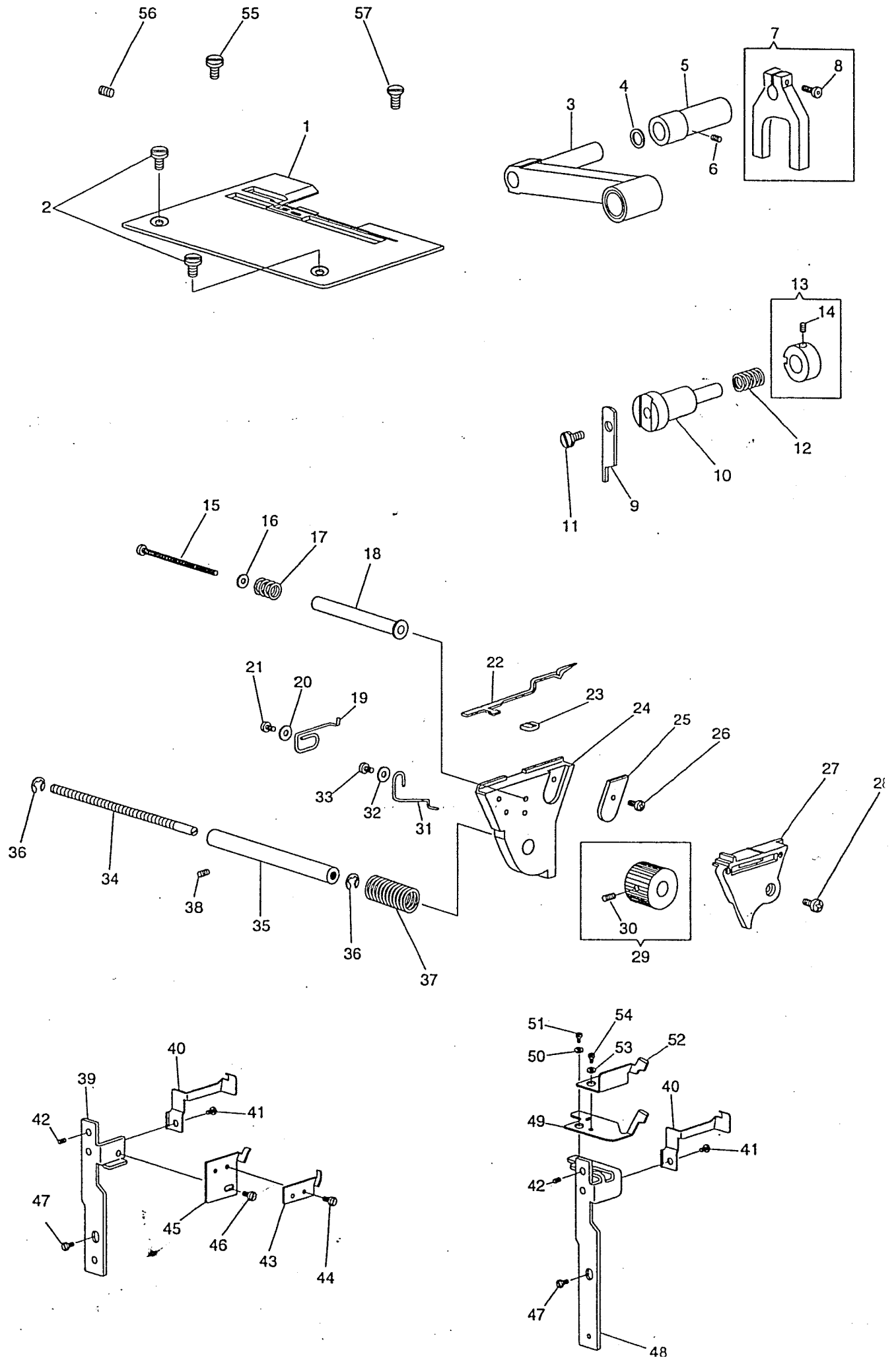

NO.	PART NO.	544	554	555	557	QTY.	DESCRIPTION
1	550443-452	*	*	-	-	1	THROAT PLATE (FOR 4 THREAD)
1	550445-452	-	-	*	-	1	THROAT PLATE (FOR 555)
1	556016-452	-	-	-	*	1	THROAT PLATE
2	550553	*	*	*	-	2	THROAT PLATE POSITION SCREW
3	550437-391	*	*	*	*	1	KNIFE (MOVABLE) LEVER COMP.
4	542402	*	*	*	*	1	KNIFE (MOVABLE) FORKED LEVER STUD BUSHING THRUST WASHER
5	550440	*	*	*	*	1	KNIFE (MOVABLE) FORKED LEVER STUD BUSHING
6	544207-011	*	*	*	*	1	KNIFE (MOVABLE) FORKED LEVER STUD BUSHING SCREW
7	550633	*	*	*	*	1	KNIFE (MOVABLE) FORKED LEVER COMP.
8	414750-004	*	*	*	*	1	KNIFE (MOVABLE) FORKED LEVER SCREW
9	412585	*	*	*	*	1	KNIFE (MOVABLE)
10	412586	*	*	*	*	1	KNIFE (MOVABLE) HOLDER
11	544407	*	*	*	*	1	KNIFE (MOVABLE) SCREW
12	410307	*	*	*	*	1	KNIFE (MOVABLE) HOLDER SPRING
13	550581	*	*	*	*	1	KNIFE (MOVABLE) HOLDER COLLAR COMP.
14	544207-011	*	*	*	*	1	KNIFE (MOVABLE) HOLDER COLLAR SCREW
15	414744-003	*	*	*	*	1	KNIFE (STATIONARY) HOLDER STUD SCREW
16	541217	*	*	*	*	1	KNIFE (STATIONARY) HOLDER STUD SCREW WASHER
17	412774	*	*	*	*	1	KNIFE (STATIONARY) HOLDER STUD SPRING
18	550457	*	*	*	*	1	KNIFE (STATIONARY) HOLDER STUD
19	550452	*	*	*	*	1	SEAM WIDTH FINGER SPRING
20	543803-002	*	*	*	*	1	SEAM WIDTH FINGER SPRING WASHER
21	544211-002	*	*	*	*	1	SEAM WIDTH FINGER SPRING SCREW
22	550450	*	*	*	-	1	SEAM WIDTH FINGER
22	556043	-	-	-	*	1	SEAM WIDTH FINGER
23	550453-391	*	*	*	*	1	SEAM WIDTH FINGER KNOB
24	550448	*	*	*	*	1	KNIFE (STATIONARY) HOLDER
25	550449	*	*	*	*	1	KNIFE (STATIONARY)
26	544211-051	*	*	*	*	1	KNIFE (STATIONARY) SCREW
27	550451-391	*	*	*	*	1	SEAM WIDTH FINGER SUPPORT PLATE
28	544211-002	*	*	*	*	1	SEAM WIDTH FINGER SUPPORT PLATE SCREW
29	550454	*	*	*	*	1	SEAM WIDTH CONTROL DIAL COMP.
30	544207-011	*	*	*	*	1	SEAM WIDTH CONTROL DIAL SCREW
31	550602	*	*	*	*	1	SEAM WIDTH CONTROL DIAL SPRING
32	543803-002	*	*	*	*	1	SEAM WIDTH CONTROL DIAL SPRING WASHER
33	544211-002	*	*	*	*	1	SEAM WIDTH CONTROL SPRING SCREW
34	550549	*	*	*	*	1	SEAM WIDTH CONTROL SCREW
35	550456	*	*	*	*	1	SEAM WIDTH CONTROL SCREW BUSHING
36	543801-003	*	*	*	*	2	SEAM WIDTH CONTROL SCREW RETAINING RING
37	550359	*	*	*	*	1	SEAM WIDTH CONTROL SCREW SPRING
38	544207-011	*	*	*	*	1	SEAM WIDTH CONTROL STUD SCREW
39	550431	*	*	*	-	1	NEEDLE GUARD BRACKET
40	550432	*	*	*	*	1	NEEDLE GUARD (FRONT) FOR OVEREDGE NEEDLE
41	544211-001	*	*	*	*	1	NEEDLE GUARD (FRONT) FOR OVEREDGE NEEDLE SCREW
42	374392-002	*	*	*	*	1	NEEDLE GUARD (FRONT) FOR OVEREDGE NEEDLE ADJUSTING SCREW
43	550434	-	-	*	-	1	NEEDLE GUARD (BACK) FOR CHAIN NEEDLE
44	544211-001	-	-	*	-	1	NEEDLE GUARD (BACK) FOR CHAIN NEEDLE SCREW
45	550435	-	-	*	-	1	NEEDLE GUARD (FRONT) FOR CHAIN NEEDLE
46	544211-001	-	-	*	-	1	NEEDLE GUARD (FRONT) FOR CHAIN NEEDLE SCREW
47	544212-001	*	*	*	*	1	NEEDLE GUARD BRACKET COMP. SCREW
48	556049	-	-	-	*	1	NEEDLE GUARD BRACKET
49	556047	-	-	-	*	1	NEEDLE GUARD (FRONT) FOR COVER STITCH NEEDLE
50	543804-002	-	-	-	*	1	NEEDLE GUARD (FRONT) FOR COVER STITCH NEEDLE SCREW WASHER
51	544211-001	-	-	-	*	1	NEEDLE GUARD (BACK) FOR COVER STITCH NEEDLE
52	556048	-	-	-	*	1	NEEDLE GUARD (BACK) FOR COVER STITCH NEEDLE SCREW
53	543804-002	-	-	-	*	1	NEEDLE GUARD (FRONT) FOR COVER STITCH NEEDLE SCREW WASHER
54	544211-001	-	-	-	*	1	NEEDLE GUARD (BACK) FOR COVER STITCH NEEDLE SCREW
55	556018	-	-	-	*	1	THROAT PLATE POSITIONING PIN (ECC.)
56	544207-001	-	-	-	*	1	THROAT PLATE POSITIONING PIN (ECC.) SET SCREW
57	374113	-	-	-	*	1	THROAT PLATE SCREW

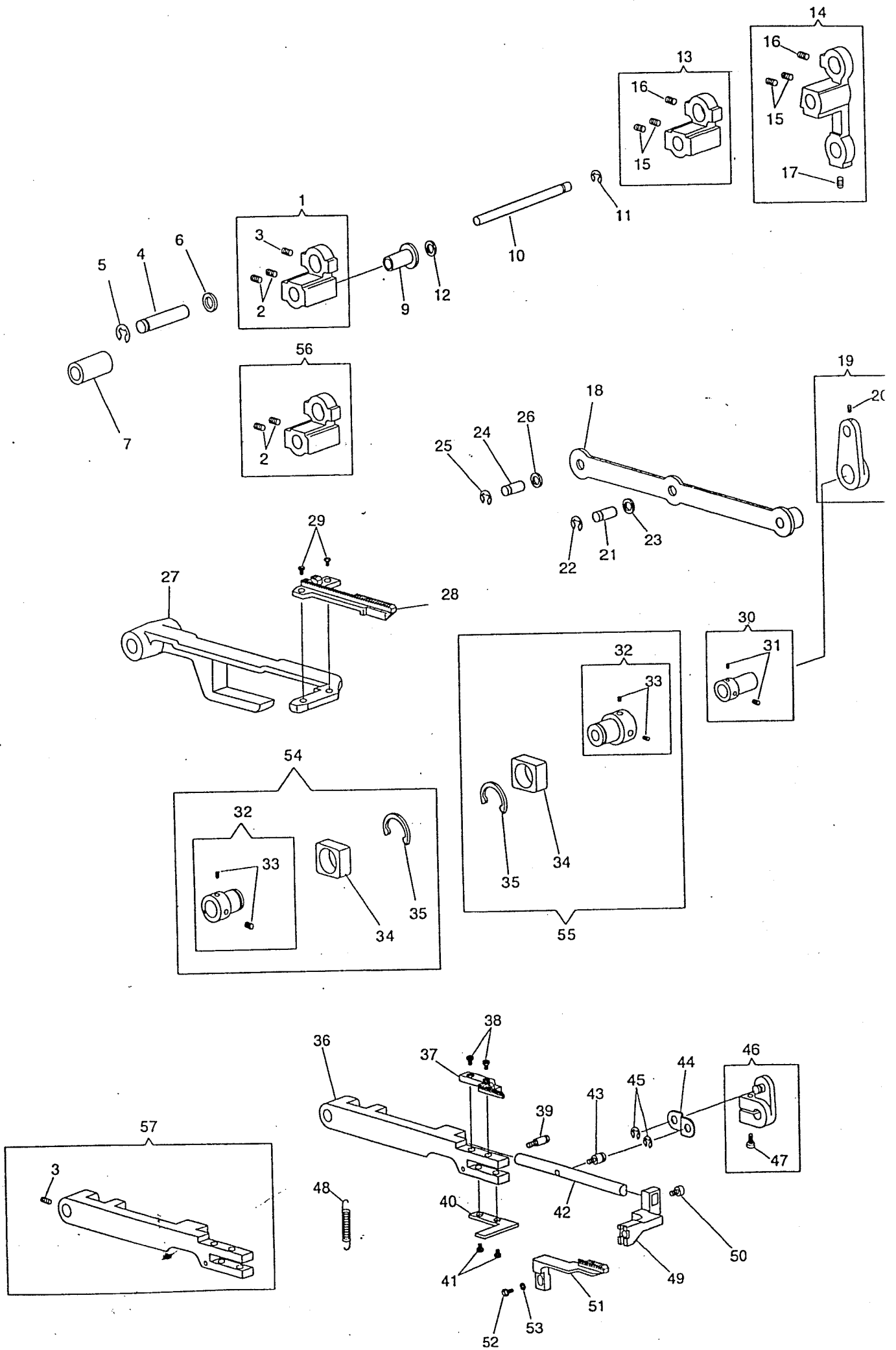

NO.	PART NO.	544	554	555	557	QTY.	DESCRIPTION
1	550467	*	*	*	-	1	FEED CRANK (LEFT) COMP.
2	544207-011	*	*	*	*	2	FEED CRANK (LEFT) SCREW
3	544207-011	*	*	*	*	1	FEED CRANK (LEFT) STUD SCREW
4	550473	*	*	*	*	1	FEED CRANK (LEFT) STUD
5	543801-006	*	*	*	*	1	FEED CRANK (LEFT) STUD RETAINING RING
6	542402	*	*	*	*	1	FEED CRANK (LEFT) STUD THRUST WASHER
7	550460	*	*	*	*	1	FEED CRANK SHAFT BUSHING (LEFT)
9	550459	*	*	*	*	1	FEED CRANK SHAFT BUSHING (RIGHT)
10	550458	*	*	*	*	1	FEED CRANK SHAFT
11	543801-005	*	*	*	*	1	FEED CRANK SHAFT BUSHING RETAINING RING
12	543531	*	*	*	*	1	FEED CRANK SHAFT THRUST WASHER
13	550467	*	-	-	-	1	FEED CRANK (RIGHT) COMP.
14	550471	-	*	*	*	1	FEED CRANK (RIGHT) (FOR DIFF. FEED) COMP.
15	544207-011	*	*	*	*	2	FEED CRANK (RIGHT) SCREW
16	544207-011	*	*	*	*	1	FEED CRANK (RIGHT) STUD SCREW
17	544207-011	-	*	*	*	1	DIFFERENTIAL FEED CRANK STUD SCREW
18	550464	*	*	*	*	1	FEED REGULATOR CRANK ROD COMP.
19	550462	*	*	*	*	1	FEED CRANK ROD COMP.
20	544207-011	*	*	*	*	1	FEED CRANK ROD PIN SCREW
21	412635	*	*	*	*	1	FEED REGULATOR CRANK ROD PIN
22	543801-006	*	*	*	*	1	FEED REGULATOR CRANK ROD PIN RETAINING RING
23	543531	*	*	*	*	1	FEED REGULATOR CRANK ROD PIN THRUST WASHER
24	550469	*	*	*	*	1	FEED CRANK (RIGHT) STUD
25	543801-006	*	*	*	*	1	FEED CRANK (RIGHT) STUD RETAINING RING
26	542402	*	*	*	*	1	FEED CRANK (RIGHT) STUD THRUST WASHER
27	550583	*	-	-	-	1	FEED BAR
28	550483	*	-	-	-	1	FEED DOG
29	544103	*	-	-	-	2	FEED DOG SCREW
30	550479	*	*	*	*	1	FEED CAM COMP.
31	544207-011	*	*	*	*	2	FEED CAM SCREW
32	550579	*	*	-	-	1	FEED LIFTING CAM COMP. (FOR 4 THREAD)
32	550640	-	-	*	*	1	FEED LIFTING CAM COMP. (FOR 5 THREAD)
33	544207-011	*	*	*	*	2	FEED LIFTING CAM SCREW
34	410387	*	*	*	*	1	FEED LIFTING CAM SLIDE BLOCK
35	543818-010	*	*	*	*	1	FEED LIFTING CAM SLIDE BLOCK RETAINING RING
36	550638	-	*	*	-	1	MAIN FEED BAR
37	550499	-	*	*	-	1	MAIN FEED DOG
37	556025	-	-	-	*	1	MAIN FEED DOG
38	544211-002	-	*	*	*	2	MAIN FEED DOG SCREW
39	550497	-	*	*	*	1	MAIN FEED BAR SPRING SCREW STUD
40	550498	-	*	*	*	1	AUXILIARY FEED SUPPORT BRACKET
41	544211-002	-	*	*	*	2	AUXILIARY FEED SUPPORT BRACKET SCREW
42	550500	-	*	*	-	1	AUXILIARY FEED BAR
42	556026	-	-	-	*	1	AUXILIARY FEED BAR
43	550503	-	*	*	*	1	AUXILIARY FEED BAR GUIDE PIN SCREW
44	550504	-	*	*	-	1	AUXILIARY FEED BAR LINK
44	556028	-	-	-	*	1	AUXILIARY FEED BAR LINK
45	543801-003	-	*	*	*	2	AUXILIARY FEED BAR LINK RETAINING RING
46	550505	-	*	*	*	1	DIFFERENTIAL FEED ARM COMP.
47	414751-001	-	*	*	*	1	DIFFERENTIAL FEED ARM SCREW
48	550509	-	*	*	*	1	MAIN FEED BAR SPRING
49	550501	-	*	*	*	1	AUXILIARY FEED DOG HOLDER
50	544211-002	-	*	*	*	1	AUXILIARY FEED DOG HOLDER SCREW
51	550502	-	*	*	-	1	AUXILIARY FEED DOG
51	556027	-	-	-	*	1	AUXILIARY FEED DOG
51	544212-003	-	*	*	*	1	AUXILIARY FEED DOG SCREW
53	543804-003	-	*	*	*	1	AUXILIARY FEED DOG SCREW WASHER
54	550578	*	*	-	-	1	FEED LIFTING CAM SLIDE BLOCK COMP. (FOR 4 THREAD)
55	550639	-	-	*	*	1	FEED LIFTING CAM SLIDE BLOCK COMP. (FOR 5 THREAD)
56	556019	-	-	-	*	1	FEED CRANK (LEFT) COMP.
57	556023	-	-	-	*	1	MAIN FEED BAR COMP.

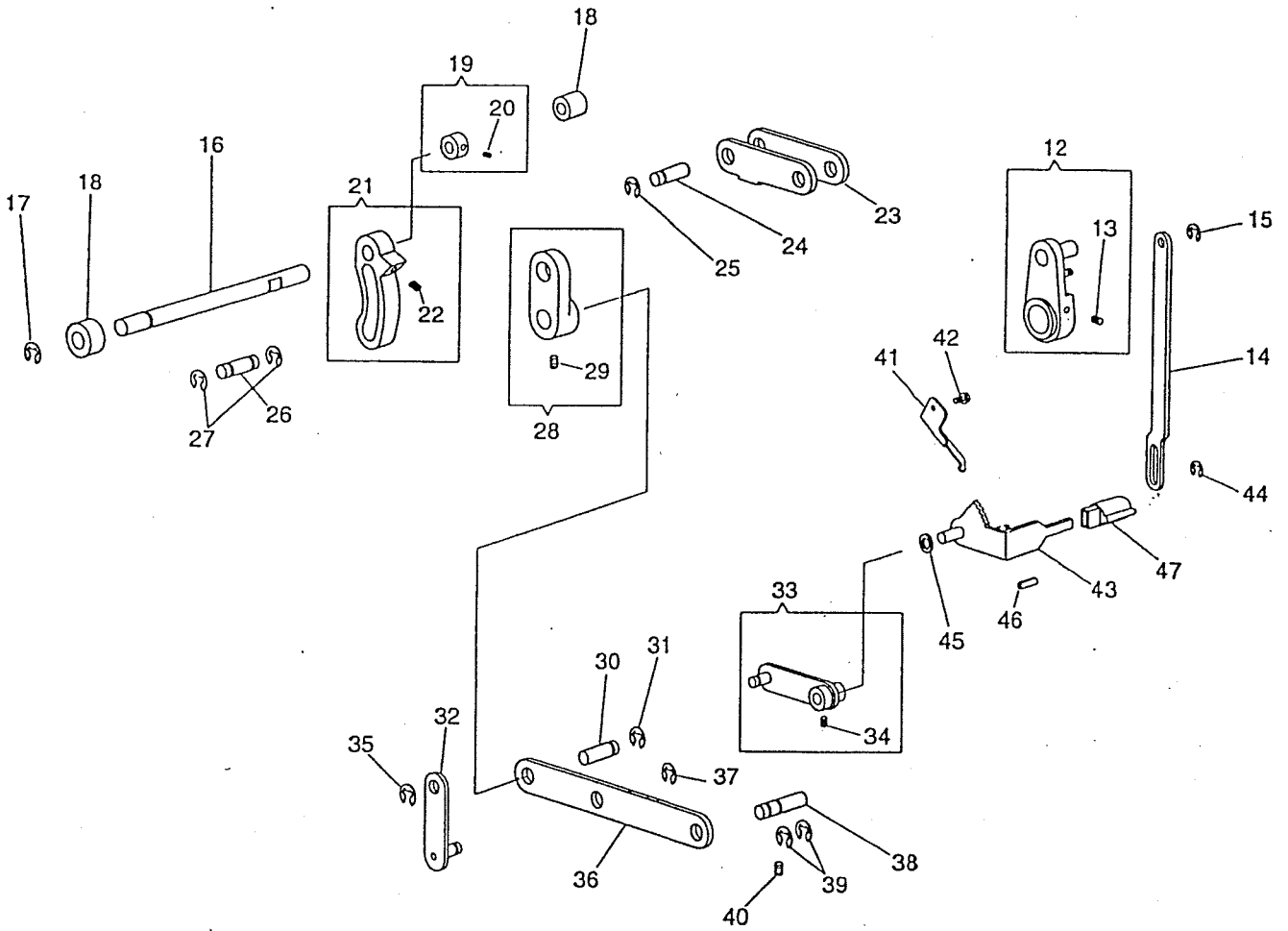
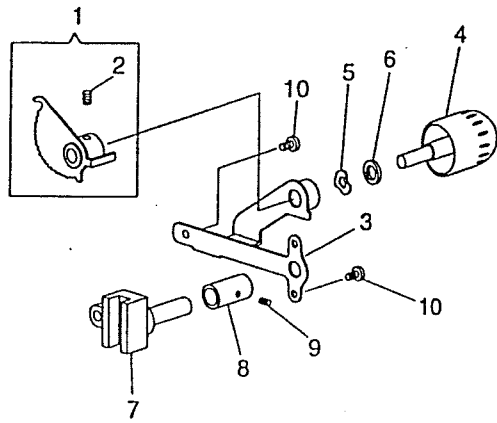

NO.	PART NO.	544	554	555	557	QTY.	DESCRIPTION
1	281406	*	*	*	*	1	FEED REGULATOR DRIVING CAM COMP.
2	544207-011	*	*	*	*	1	FEED REGULATOR DRIVING CAM SCREW
3	550485	*	*	*	*	1	FEED DIAL HUB COMP.
4	550487-401	*	*	*	*	1	FEED DIAL (GRAPHIC)
5	409213	*	*	*	*	1	FEED DIAL WAVE WASHER
6	543803-005	*	*	*	*	1	FEED DIAL WASHER
7	281401	*	*	*	*	1	FEED REGULATOR
8	410370	*	*	*	*	1	FEED REGULATOR STUD BUSHING
9	544207-011	*	*	*	*	1	FEED REGULATOR STUD BUSHING SET SCREW
10	544212-001	*	*	*	*	2	FEED DIAL HUB BRACKET
11	281485	*	*	*	*	1	FEED REGULATOR LEVER SPRING
12	281413	*	-	-	-	1	FEED REGULATOR LEVER COMP.
12	550490	-	*	*	*	1	FEED REGULATOR LEVER COMP.
13	544207-011	*	*	*	*	1	FEED REGULATOR LEVER SCREW
14	550523	-	*	*	*	1	DIFFERENTIAL FEED SAFETY PLATE
15	543801-002	-	*	*	*	1	DIFFERENTIAL FEED SAFETY PLATE RETAINING RING
16	550510	-	*	*	*	1	DIFFERENTIAL FEED SHAFT
17	543801-006	-	*	*	*	1	DIFFERENTIAL FEED SHAFT RETAINING RING
18	410324	-	*	*	*	2	DIFFERENTIAL FEED SHAFT BUSHING
19	375390	-	*	*	*	1	DIFFERENTIAL FEED SHAFT COLLAR COMP.
20	544207-011	-	*	*	*	1	DIFFERENTIAL FEED SHAFT COLLAR SCREW
21	550584	-	*	*	*	1	DIFFERENTIAL FEED ADJUSTING ARM COMP.
22	544207-011	-	*	*	*	1	DIFFERENTIAL FEED ADJUSTING ARM SCREW
23	412622	-	*	*	*	1	DIFFERENTIAL FEED CRANK ROD
24	412620	-	*	*	*	1	DIFFERENTIAL FEED CRANK STUD
25	543801-006	-	*	*	*	1	DIFFERENTIAL FEED CRANK STUD RETAINING RING
26	412627	-	*	*	*	1	DIFFERENTIAL FEED CRANK ROD STUD
27	543801-006	-	*	*	*	2	DIFFERENTIAL FEED CRANK ROD STUD RETAINING RING
28	550586	-	*	*	*	1	DIFFERENTIAL FEED ADJUSTING LEVER ARM COMP.
29	544207-011	-	*	*	*	1	DIFFERENTIAL FEED ADJUSTING LEVER ARM PIN SCREW
30	412635	-	*	*	*	1	DIFFERENTIAL FEED ADJUSTING LEVER ARM PIN
31	543801-006	-	*	*	*	1	DIFFERENTIAL FEED ADJUSTING LEVER ARM PIN RETAINING RING
32	550519	-	*	*	*	1	DIFFERENTIAL FEED LEVER LINK COMP.
33	550572	-	*	*	*	1	DIFFERENTIAL FEED LEVER COMP.
34	544207-011	-	*	*	*	1	DIFFERENTIAL FEED ADJUSTING LEVER SCREW
35	543801-005	-	*	*	*	1	DIFFERENTIAL FEED LEVER RETAINING RING
36	412637	-	*	*	*	1	DIFFERENTIAL FEED ADJUSTING LEVER (LOWER)
37	543801-006	-	*	*	*	1	DIFFERENTIAL FEED ADJUSTING LEVER (LOWER) RETAINING RING
38	412644	-	*	*	*	1	DIFFERENTIAL FEED ADJUSTING LEVER STUD
39	543801-006	-	*	*	*	2	DIFFERENTIAL FEED ADJUSTING LEVER STUD RETAINING RING
40	544207-011	-	*	*	*	1	DIFFERENTIAL FEED ADJUSTING LEVER STUD SCREW
41	550524	-	*	*	*	1	DIFFERENTIAL FEED ADJUSTING LEVER SPRING
42	544270-001	-	*	*	*	1	DIFFERENTIAL FEED ADJUSTING LEVER SPRING SCREW
43	550511	-	*	*	*	1	DIFFERENTIAL FEED ADJUSTING LEVER COMP.
44	543801-002	-	*	*	*	1	DIFFERENTIAL FEED SAFETY PLATE RETAINING RING
45	543803-005	-	*	*	*	1	DIFFERENTIAL FEED ADJUSTING LEVER WASHER
46	543808-003	-	*	*	*	1	DIFFERENTIAL FEED ADJUSTING LEVER PIN
47	550522-381	-	*	*	*	1	DIFFERENTIAL FEED ADJUSTING LEVER KNOB

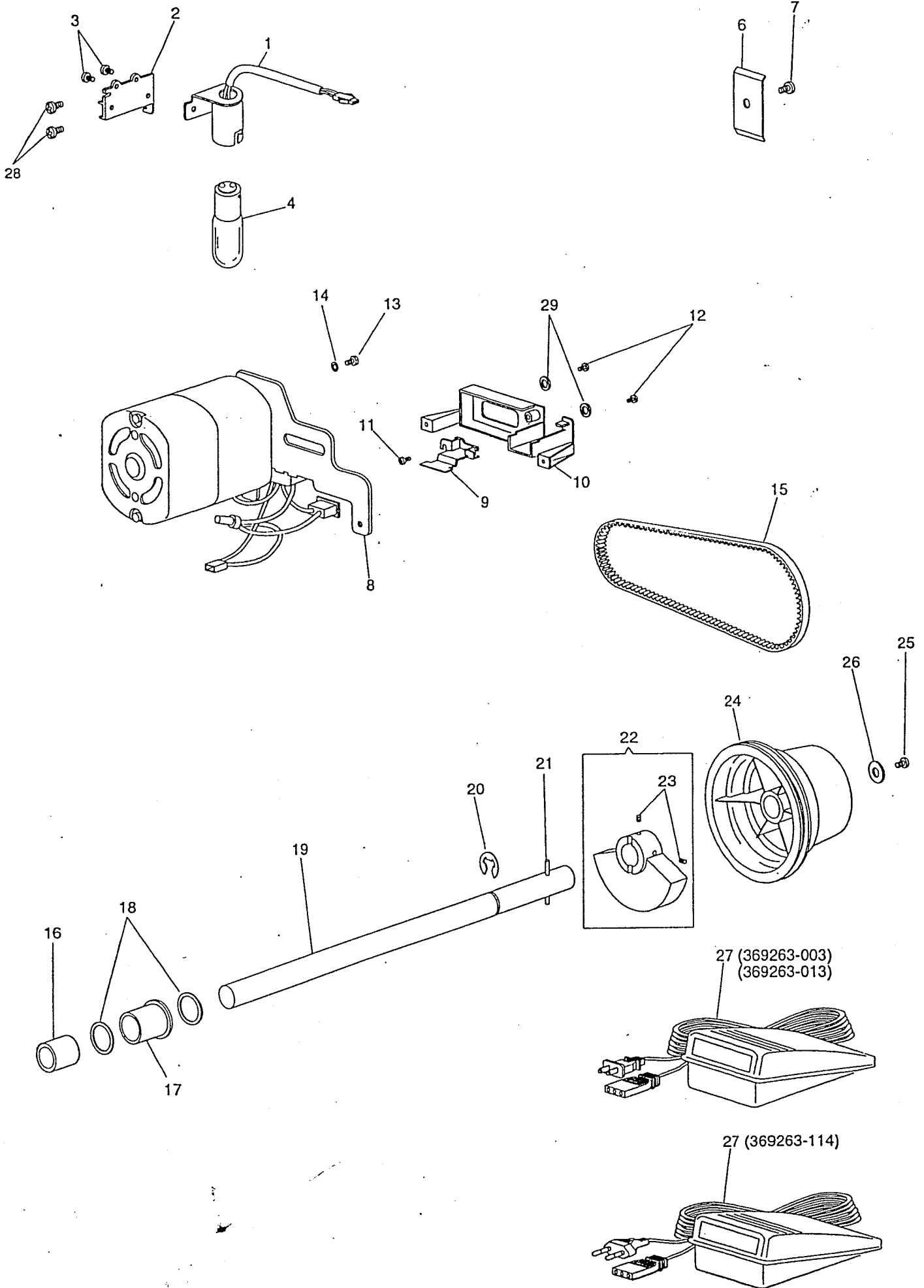

NO.	PART NO.	544	554	555	557	QTY.	DESCRIPTION
1	369308	*	*	*	*	1	LAMP HOLDER COMP. (FOR 120-127V)
2	281459	*	*	*	*	1	LAMP HOLDER BRACKET
3	544211-002	*	*	*	*	2	LAMP HOLDER COMP. SCREW
4	194120-019	*	*	*	*	1	LAMP (FOR 120V 15W)
6	550600	*	*	*	*	1	CORD CLAMPING PLATE
7	544212-001	*	*	*	*	1	CORD CLAMPING PLATE SCREW
8	369310	*	*	*	*	1	MOTOR COMP. (FOR 120V)
8	369324	*	*	*	*	1	MOTOR COMP. (FOR 127V)
9	550530-391	*	*	*	*	1	SWITCH BOX (UPPER)
10	550554-391	*	*	*	*	1	SWITCH BOX (LOWER) (FOR 100-127V)
11	544248-002	*	*	*	*	1	SWITCH BOX (UPPER) SCREW
12	544211-002	*	*	*	*	2	SWITCH BOX (LOWER) SCREW
13	544499-001	*	*	*	*	1	MOTOR BRACKET SCREW
14	543805-005	*	*	*	*	1	MOTOR BRACKET SCREW WASHER
15	412721	*	*	*	*	1	MOTOR BELT
16	410252	*	*	*	*	1	ROTATING SHAFT BUSHING (LEFT)
17	410253	*	*	*	*	1	ROTATING SHAFT BUSHING (RIGHT)
18	408730	*	*	*	*	2	ROTATING SHAFT THRUST WASHER
19	550526	*	*	*	*	1	ROTATING SHAFT
20	543801-010	*	*	*	*	1	ROTATING SHAFT RETAINING RING
21	543808-004	*	*	*	*	1	ROTATING SHAFT SPRING PIN
22	550527	*	*	*	*	1	ROTATING SHAFT BALANCE WEIGHT COMP.
23	544207-011	*	*	*	*	2	ROTATING SHAFT BALANCE WEIGHT COMP. SCREW
24	550529-381	*	*	*	*	1	PULLEY
25	544270-001	*	*	*	*	1	PULLEY SET SCREW
26	543848	*	*	*	*	1	PULLEY SET SCREW WASHER
27	369263-003	*	*	*	*	1	CONTROLLER COMP. (FOR 110-120V) (FOR USA/ CANADA)
27	369263-013	*	*	*	*	1	CONTROLLER COMP. (FOR 127V) (FOR SAUDI ARABIA)
27	369263-114	*	*	*	*	1	CONTROLLER COMP. (FOR 127V) (FOR BRAZIL)
28	544212-002	*	*	*	*	2	LAMP HOLDER BRACKET SCREW
29	543905-003	*	*	*	*	2	SWITCH BOX (LOWER) SCREW WASHER

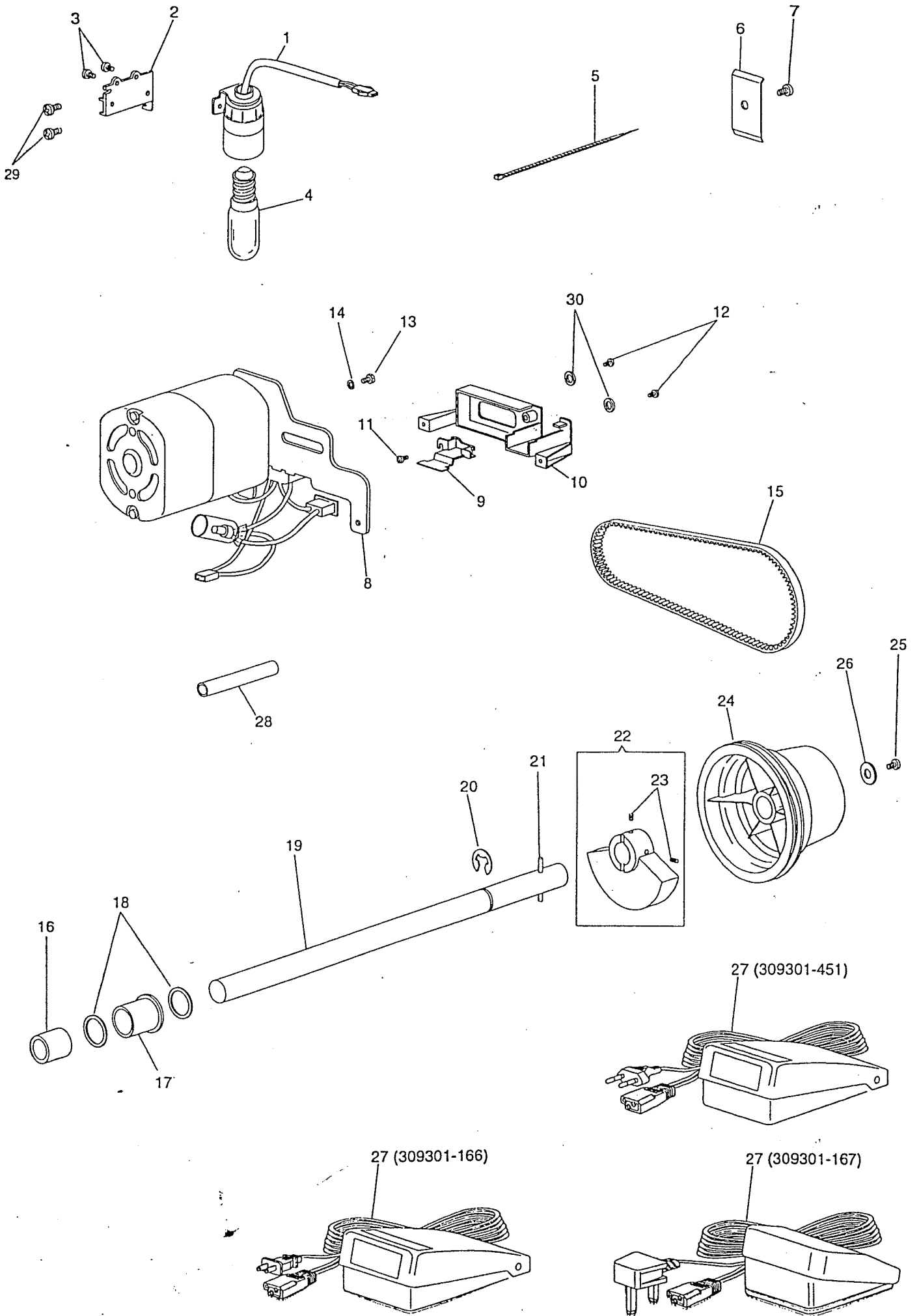

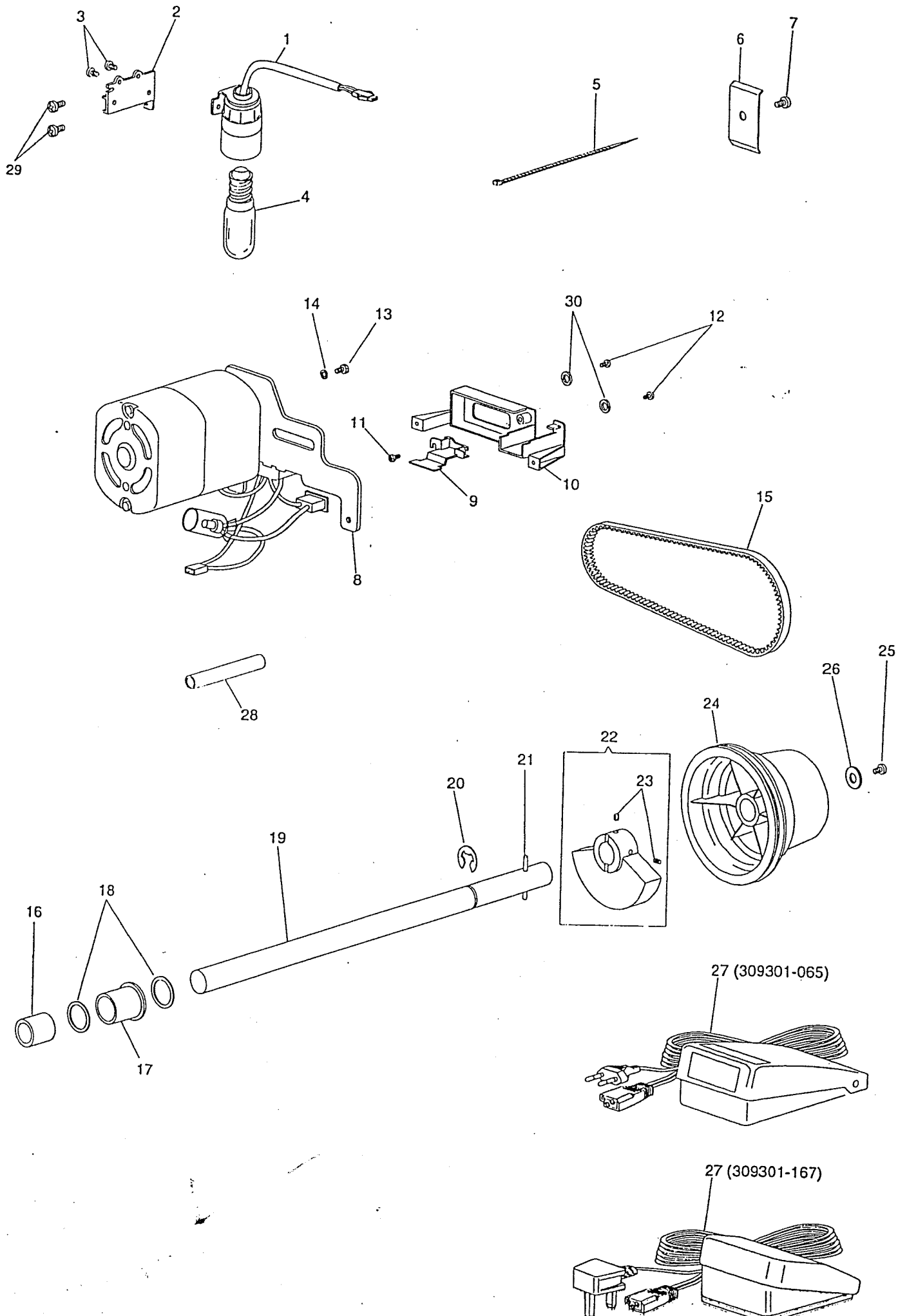

NO.	PART NO.	544	554	555	557	QTY.	DESCRIPTION
1	369316	*	*	*	*	1	LAMP HOLDER COMP. (FOR 200-240V)
2	281459	*	*	*	*	1	LAMP HOLDER BRACKET
3	544211-002	*	*	*	*	2	LAMP HOLDER COMP. SCREW
4	369215-001	*	*	*	*	1	LAMP (FOR 220-240V 15W)
5	543879	*	*	*	*	1	CORD HOLDER
6	550600	*	*	*	*	1	CORD CLAMPING PLATE
7	544212-001	*	*	*	*	1	CORD CLAMPING PLATE SCREW
8	369328	*	*	*	*	1	MOTOR COMP. (FOR 220V)
9	550530-391	*	*	*	*	1	SWITCH BOX (UPPER)
10	550555-391	*	*	*	*	1	SWITCH BOX (LOWER) (FOR 200-240V)
11	544248-002	*	*	*	*	1	SWITCH BOX (UPPER) SCREW
12	544211-002	*	*	*	*	2	SWITCH BOX (LOWER) SCREW
13	544499-001	*	*	*	*	1	MOTOR BRACKET SCREW
14	543805-005	*	*	*	*	1	MOTOR BRACKET SCREW WASHER
15	412721	*	*	*	*	1	MOTOR BELT
16	410252	*	*	*	*	1	ROTATING SHAFT BUSHING (LEFT)
17	410253	*	*	*	*	1	ROTATING SHAFT BUSHING (RIGHT)
18	408730	*	*	*	*	2	ROTATING SHAFT THRUST WASHER
19	550526	*	*	*	*	1	ROTATING SHAFT
20	543801-010	*	*	*	*	1	ROTATING SHAFT RETAINING RING
21	543808-004	*	*	*	*	1	ROTATING SHAFT SPRING PIN
22	550527	*	*	*	*	1	ROTATING SHAFT BALANCE WEIGHT COMP.
23	544207-011	*	*	*	*	2	ROTATING SHAFT BALANCE WEIGHT COMP. SCREW
24	550529-381	*	*	*	*	1	PULLEY
25	544270-001	*	*	*	*	1	PULLEY SET SCREW
26	543848	*	*	*	*	1	PULLEY SET SCREW WASHER
27	369301-451	*	*	*	*	1	CONTROLLER COMP. (FOR 220-250V)
27	369301-166	*	*	*	*	1	CONTROLLER COMP. (FOR 220V) (FOR PHILIPPINES)
27	369301-167	*	*	*	*	1	CONTROLLER COMP. (FOR 230V) (FOR HONG KONG)
28	419161-906	*	*	*	*	1	TUBE (FOR 200-240V)
29	544212-002	*	*	*	*	2	LAMP HOLDER BRACKET SCREW
30	543905-003	*	*	*	*	2	SWITCH BOX (LOWER) SCREW WASHER

NO.	PART NO.	544	554	555	557	QTY.	DESCRIPTION
1	369316	*	*	*	*	1	LAMP HOLDER COMP. (FOR 200-240V)
2	281459	*	*	*	*	1	LAMP HOLDER BRACKET
3	544211-002	*	*	*	*	2	LAMP HOLDER COMP. SCREW
4	369215-001	*	*	*	*	1	LAMP (FOR 220-240V 15W)
5	543879	*	*	*	*	1	CORD HOLDER
6	550600	*	*	*	*	1	CORD CLAMPING PLATE
7	544212-001	*	*	*	*	1	CORD CLAMPING PLATE SCREW
8	369313	*	*	*	*	1	MOTOR COMP. (FOR 230V)
9	550530-391	*	*	*	*	1	SWITCH BOX (UPPER)
10	550555-391	*	*	*	*	1	SWITCH BOX (LOWER) (FOR 200-240V)
11	544248-002	*	*	*	*	1	SWITCH BOX (UPPER) SCREW
12	544211-002	*	*	*	*	2	SWITCH BOX (LOWER) SCREW
13	544499-001	*	*	*	*	1	MOTOR BRACKET SCREW
14	543805-005	*	*	*	*	1	MOTOR BRACKET SCREW WASHER
15	412721	*	*	*	*	1	MOTOR BELT
16	410252	*	*	*	*	1	ROTATING SHAFT BUSHING (LEFT)
17	410253	*	*	*	*	1	ROTATING SHAFT BUSHING (RIGHT)
18	408730	*	*	*	*	2	ROTATING SHAFT THRUST WASHER
19	550526	*	*	*	*	1	ROTATING SHAFT
20	543801-010	*	*	*	*	1	ROTATING SHAFT RETAINING RING
21	543808-004	*	*	*	*	1	ROTATING SHAFT SPRING PIN
22	550527	*	*	*	*	1	ROTATING SHAFT BALANCE WEIGHT COMP.
23	544207-011	*	*	*	*	2	ROTATING SHAFT BALANCE WEIGHT COMP. SCREW
24	550529-381	*	*	*	*	1	PULLEY
25	544270-001	*	*	*	*	1	PULLEY SET SCREW
26	543848	*	*	*	*	1	PULLEY SET SCREW WASHER
27	369301-065	*	*	*	*	1	CONTROLLER COMP. (FOR 230V) (FOR EUROPE)
27	369301-167	*	*	*	*	1	CONTROLLER COMP. (FOR 230V) (FOR U.K)
28	419161-906	*	*	*	*	1	TUBE (FOR 200-240V)
29	544212-002	*	*	*	*	2	LAMP HOLDER BRACKET SCREW
30	543905-003	*	*	*	*	2	SWITCH BOX (LOWER) SCREW WASHER

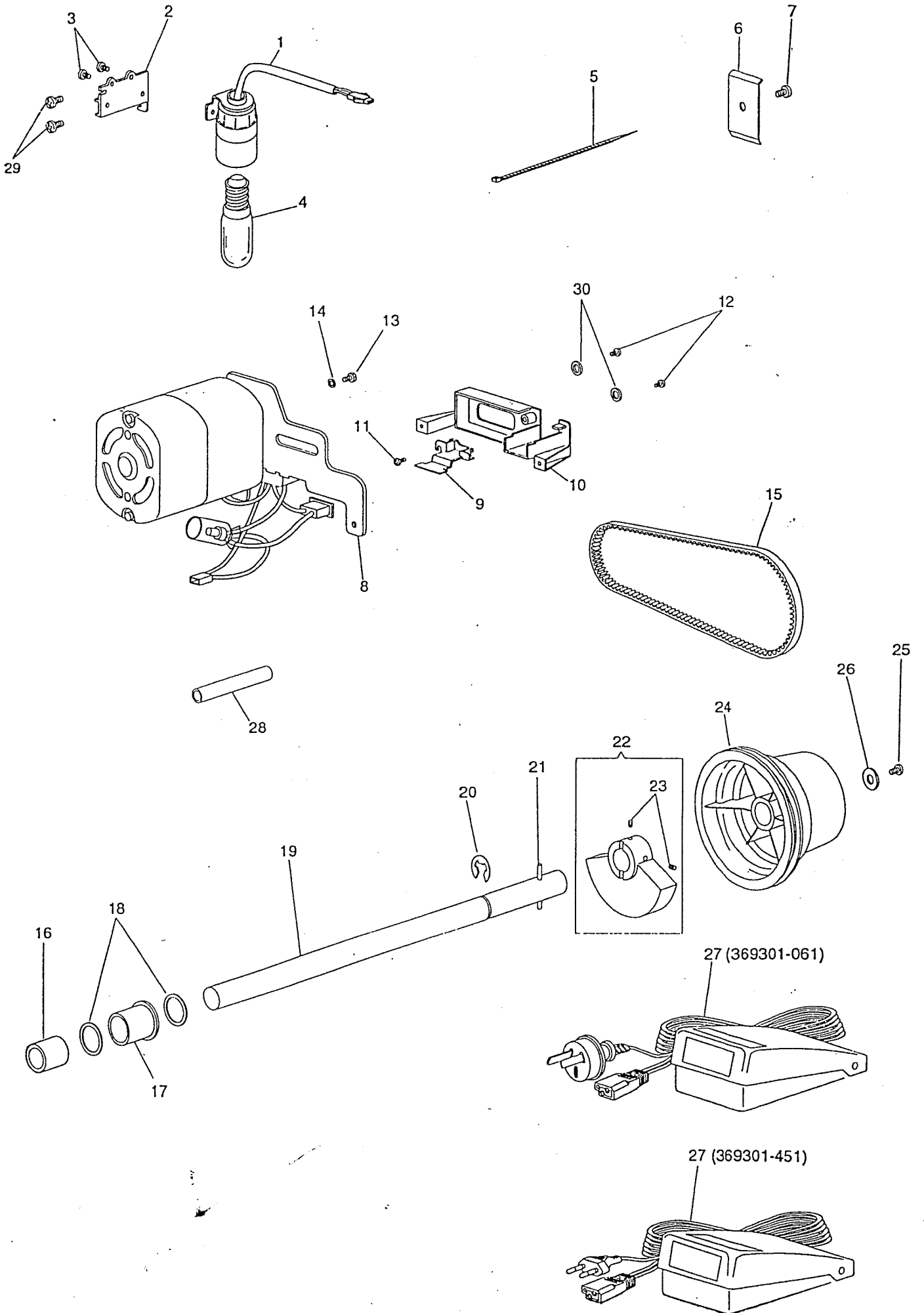

NO.	PART NO.	544	554	555	557	QTY.	DESCRIPTION
1	369316	*	*	*	*	1	LAMP HOLDER COMP. (FOR 200-240V)
2	281459	*	*	*	*	1	LAMP HOLDER BRACKET
3	544211-002	*	*	*	*	2	LAMP HOLDER COMP. SCREW
4	369215-001	*	*	*	*	1	LAMP (FOR 220-240V 15W)
5	543879	*	*	*	*	1	CORD HOLDER
6	550600	*	*	*	*	1	CORD CLAMPING PLATE
7	544212-001	*	*	*	*	1	CORD CLAMPING PLATE SCREW
8	369330	*	*	*	*	1	MOTOR COMP. (FOR 240V)
9	550530-391	*	*	*	*	1	SWITCH BOX (UPPER)
10	550555-391	*	*	*	*	1	SWITCH BOX (LOWER) (FOR 200-240V)
11	544248-002	*	*	*	*	1	SWITCH BOX (UPPER) SCREW
12	544211-002	*	*	*	*	2	SWITCH BOX (LOWER) SCREW
13	544499-001	*	*	*	*	1	MOTOR BRACKET SCREW
14	543805-005	*	*	*	*	1	MOTOR BRACKET SCREW WASHER
15	412721	*	*	*	*	1	MOTOR BELT
16	410252	*	*	*	*	1	ROTATING SHAFT BUSHING (LEFT)
17	410253	*	*	*	*	1	ROTATING SHAFT BUSHING (RIGHT)
18	408730	*	*	*	*	2	ROTATING SHAFT THRUST WASHER
19	550526	*	*	*	*	1	ROTATING SHAFT
20	543801-010	*	*	*	*	1	ROTATING SHAFT RETAINING RING
21	543808-004	*	*	*	*	1	ROTATING SHAFT SPRING PIN
22	550527	*	*	*	*	1	ROTATING SHAFT BALANCE WEIGHT COMP.
23	544207-011	*	*	*	*	2	ROTATING SHAFT BALANCE WEIGHT COMP. SCREW
24	550529-381	*	*	*	*	1	PULLEY
25	544270-001	*	*	*	*	1	PULLEY SET SCREW
26	543848	*	*	*	*	1	PULLEY SET SCREW WASHER
27	369301-061	*	*	*	*	1	CONTROLLER COMP. (FOR 220-250V) (FOR AUSTRALIA)
27	369301-451	*	*	*	*	1	CONTROLLER COMP. (FOR 220-250V)
28	419161-906	*	*	*	*	1	TUBE (FOR 200-240V)
29	544212-002	*	*	*	*	2	LAMP HOLDER BRACKET SCREW
30	543905-003	*	*	*	*	2	SWITCH BOX (LOWER) SCREW WASHER

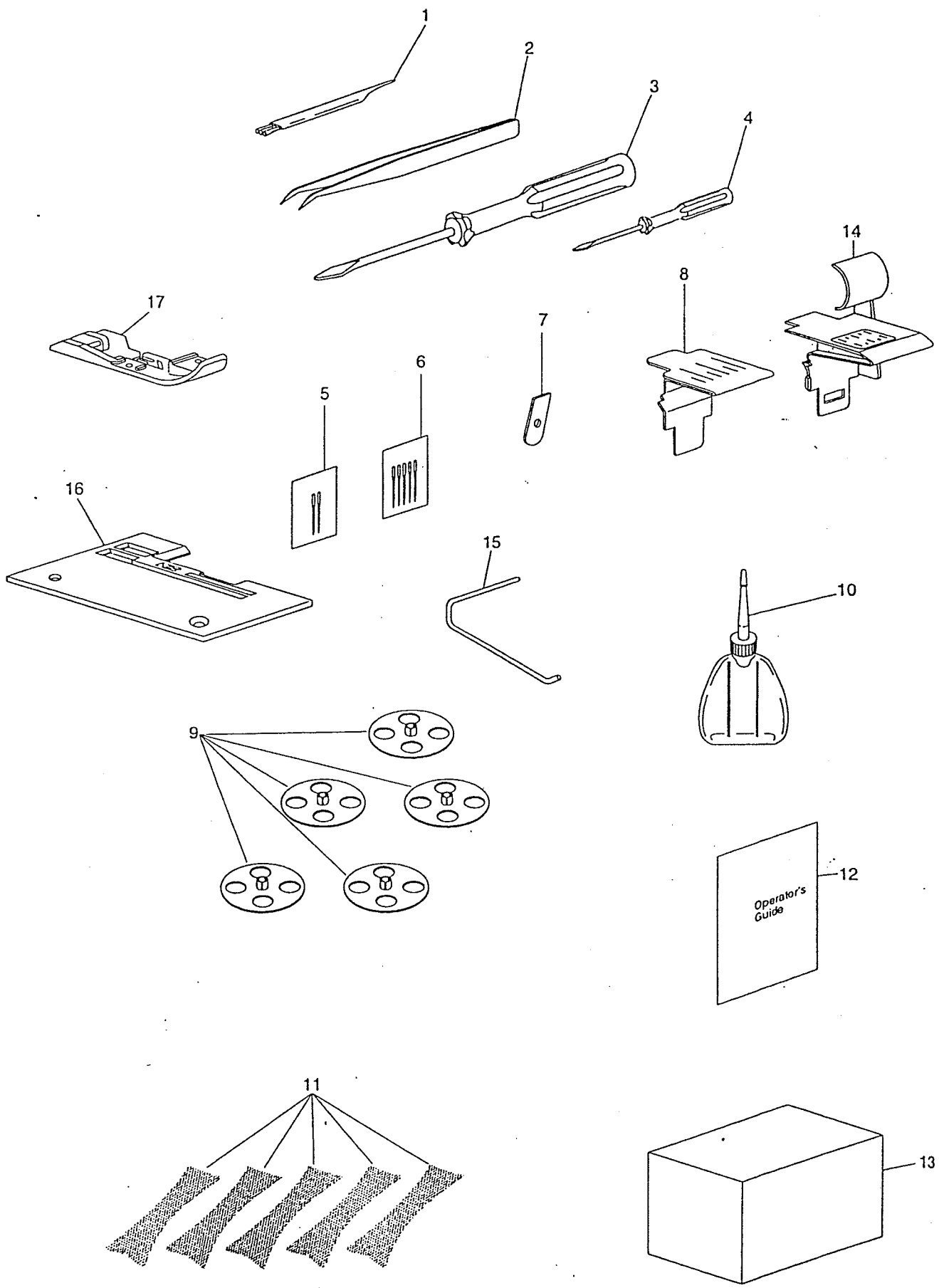

NO.	PART NO.	544	554	555	557	QTY.	DESCRIPTION
1	546358	*	*	*	*	1	BRUSH
2	376638	*	*	*	*	1	TWEEZERS
3	541513-946	*	*	*	*	1	SCREW DRIVER (MEDIUM)
4	541514	*	*	*	*	1	SCREW DRIVER (SMALL)
5	410189	*	*	-	-	1	NEEDLE PACK(N2054-42#14 X 2)
6	410190	-	-	*	*	1	NEEDLE PACK(N2054-42#14 X 3,#10 X 2)
7	550449	*	*	*	*	1	KNIFE (STATIONARY)
8	412520	-	-	*	-	1	CHAIN STITCH SEAM WIDTH GAGE
9	546894	*	*	-	-	4	THREAD UNWINDER SPOOL CAP
9	546894	-	-	*	*	5	THREAD UNWINDER SPOOL CAP
10	550610	*	*	*	*	1	OILER
11	543131	*	*	*	*	4	THREAD UNWINDER SPOOL NET
11	543131	-	-	*	*	5	THREAD UNWINDER SPOOL NET
12	378976-002	*	*	*	-	1	OPERATOR'S GUIDE (ENGLISH)
12	378856-003	*	*	*	-	1	OPERATOR'S GUIDE (SPANISH)
12	378856-004	*	*	*	-	1	OPERATOR'S GUIDE (PORTUGUESE)
12	378856-005	*	*	*	-	1	OPERATOR'S GUIDE (FRENCH)
12	378856-007	*	*	*	-	1	OPERATOR'S GUIDE (GERMAN)
12	378856-010	*	*	*	-	1	OPERATOR'S GUIDE (DUTCH)
12	378856-011	*	*	*	-	1	OPERATOR'S GUIDE (FINNISH)
12	378856-012	*	*	*	-	1	OPERATOR'S GUIDE (SWEDISH)
12	378856-013	*	*	*	-	1	OPERATOR'S GUIDE (ITALIAN)
12	378856-014	*	*	*	-	1	OPERATOR'S GUIDE (DANISH)
12	378856-016	*	*	*	-	1	OPERATOR'S GUIDE (NORWEGIAN)
12	378566-002	-	-	-	*	1	OPERATOR'S GUIDE (ENGLISH)
12	378566-003	-	-	-	*	1	OPERATOR'S GUIDE (SPANISH)
12	378566-004	-	-	-	*	1	OPERATOR'S GUIDE (PORTUGUESE)
12	378566-005	-	-	-	*	1	OPERATOR'S GUIDE (FRENCH)
12	378566-007	-	-	-	*	1	OPERATOR'S GUIDE (GERMAN)
12	378566-010	-	-	-	*	1	OPERATOR'S GUIDE (DUTCH)
12	378566-011	-	-	-	*	1	OPERATOR'S GUIDE (FINNISH)
12	378566-012	-	-	-	*	1	OPERATOR'S GUIDE (SWEDISH)
12	378566-013	-	-	-	*	1	OPERATOR'S GUIDE (ITALIAN)
12	378566-014	-	-	-	*	1	OPERATOR'S GUIDE (DANISH)
12	378856-016	-	-	-	*	1	OPERATOR'S GUIDE (NORWEGIAN)
13	410196-401	*	*	*	*	1	MACHINE COVER (WITH SINGER MARK)
14	556029-391	-	-	-	*	1	SEAM GUIDE PLATE
15	556033	-	-	-	*	1	SEAM GUIDE
16	556032-452	-	-	-	*	1	COVER STITCH THROAT PLATE
17	556030-452	-	-	-	*	1	COVER STITCH PRESSER FOOT