

Parts list

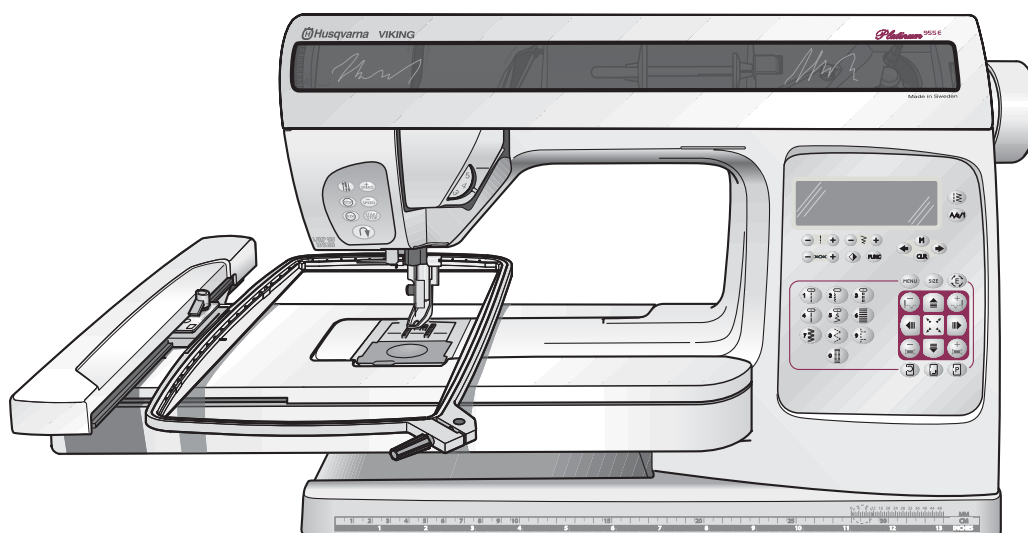

PLATINUM 955E

Part no	Description	Page	Part no	Description	Page
411 78 10-03	Light bulb	E	412 35 33-02	Driving wheel compl.	B
411 96 68-01	Screw	A,E,M,N	412 35 42-01	Pulley	H
411 96 68-03	Screw	A,F	412 35 62-01	Pin	B
411 96 68-04	Screw	E	412 36 83-04	Arm shaft	G
411 96 68-07	Screw	M	412 36 84-01	Cog belt	G
411 96 68-08	Screw	M	412 36 87-01	Pin	G
411 96 68-10	Screw	B	412 37 11-01	Thread reel disc 20 mm	A
411 96 68-12	Screw	B	412 37 11-02	Thread reel disc 40 mm	A
411 96 68-20	Srew	F	412 37 82-01	Nut	C
411 96 68-21	Srew	E	412 38 42-02	Cog wheel	M,N
411 96 68-25	Screw	F	412 38 43-01	Washer	J,M,N
411 96 68-27	Screw	J	412 38 81-04	Flex cable	A
411 96 71-07	Screw	B	412 39 12-01	Spring presserfoot lifter	E
411 96 72-05	Screw M 3*8	M	412 39 47-01	Washer	D
411 96 72-12	Screw	J	412 39 90-01	Nut	O
411 96 73-06	Screw 25*6	N	412 40 97-01	Screw	F
411 96 81-01	Screw	D	412 41 12-01	Ankle	F
411 96 87-03	Screw M3*3	E,I	412 42 37-01	Thread knife	A,D
411 96 87-16	Screw M5*5	G	412 44 68-01	Screw	O
411 96 88-16	Screw M5*5	G	412 44 69-01	Grip, hoop	O
411 96 88-20	Screw M6*10	B	412 45 23-01	Thread knife	A
411 98 14-01	Washer	C,O	412 45 24-01	Holder, thread knife	A
412 05 60-01	Screw M5*14	B	412 45 55-01	Spring	J
412 05 60-04	Screw M3*6	B,I,M	412 45 56-01	Adjusting sleeve	J
412 05 60-06	Screw M4*12	B,G,H,I	412 45 57-01	Bracket and lever	J
412 05 60-07	Screw M4*16	J	412 45 58-01	Sensor	J
412 05 60-10	Screw	B	412 45 59-01	Plugg, Thread tension	J
412 05 60-11	Screw M3*5	C,D,M,N	412 45 60-01	Thread sensor board cabel	J
412 05 60-12	Screw M 4*6	M,N	412 45 64-01	Cog wheel	J
412 14 30-05	Fuse 6.3 A (220/240V)	B	412 45 68-01	Guide	J
412 14 30-06	Fuse 2 A (220/240V)	B	412 45 69-01	Gear segment	J
412 14 32-03	Fuse 3.5 (100/120V)	B	412 45 70-02	Stepmotor Thread tension	J
412 14 32-05	Fuse 2 A (100/120V)	B	412 45 72-01	Cog wheel	J
412 15 78-01	Cord device, stand.	K	412 45 74-01	Gear Rack	J
412 15 79-02	Cord device, Japan	K	412 45 83-01	Plug	J
412 15 79-03	Cord device, USA, Can.	K	412 45 91-01	Hook cover, window	D
412 15 80-02	Cord device, England	K	412 46 44-01	Adjusting screw, thread tension	D
412 15 81-01	Cord device, Australia	K	412 46 45-01	Screw, thread tension	D
412 15 98-01	Spring	K	412 47 16-01	Thread tension compl.	D
412 18 45-01	Foot	K	412 47 73-01	Bobbincase holder	D
412 21 14-01	Screw	J,F	412 48 09-01	Protector, take up	A
412 21 14-03	Screw, torx M3*8	F	412 48 86-02	Cable holder	J
412 21 14-04	Screw	E	412 48 87-01	Cog wheel cpl	J
412 21 14-06	Screw	F	412 49 49-01	Distance sleeve	B
412 21 14-11	Screw	D	412 50 06-01	Bearing	E,F
412 21 14-14	Screw, torx M4*16	B	412 50 08-01	Gear segment	F
412 22 98-01	Locking nut	I	412 50 09-01	Spring	F
412 28 19-02	Screw	C,E	412 50 10-01	Spring	F
412 28 54-02	Presser bar	F	412 50 11-01	Link	F
412 28 75-01	Base plate	B	412 50 15-01	Bearing	F
412 28 79-01	Screw	D	412 50 22-01	Setting plate	F
412 28 79-02	Screw	J	412 50 23-02	Eccentric / needle adj.	F
412 30 06-01	Driver	G	412 50 24-01	Cross head compl.	F
412 30 07-01	Spring	G	412 50 27-01	Calibration stop	E
412 30 08-01	Pulley	G	412 50 46-01	Wedge	F
412 30 09-02	Hand wheel	G	412 50 47-01	Clamp ring	F
412 30 16-01	Link	J	412 50 48-01	Clampring	E
412 30 30-01	Guide arm	E	412 50 72-01	Spring	I
412 30 50-01	Foot	B	412 51 36-04	Feed dog cpl,	C
412 30 55-01	Rubber ring	A	412 51 37-01	Guide cpl with carrier	C
412 30 74-01	Damper	D	412 51 43-01	Guide blocks	C
412 31 44-01	Cable standard	K	412 51 44-01	Feed carriage	C
412 31 44-02	Cable USA, Can, Japan	K	412 51 49-01	Spring	C
412 31 60-49	Pin	N	412 51 53-01	Spring	C
412 31 69-01	Spring	F	412 51 54-01	Feed Lift	C
412 31 79-01	Clutch	G	412 51 63-01	Worm gear	H
412 31 81-01	Clamp, lower shaft	D,H	412 51 68-02	Lower shaft compl.	H
412 31 84-01	Bushing, feed dog	C	412 51 69-01	Eccentric feed	H
412 31 89-01	Control Unit	K	412 51 70-01	Distance	H
412 32 27-05	Bobbin winding	B	412 52 09-01	Thread holder	A
412 32 33-02	Rubber washer	A	412 52 10-01	Reel pin	A
412 32 34-09	Step motor, feeding	I	412 52 14-01	Spring	A
412 32 34-10	Step motor, sewing head	E	412 52 40-01	Step motor Y-unit compl	N
412 32 47-01	Lever thread tension	J	412 52 42-01	Cable, embroidery unit	M
412 32 49-01	Screw thread tension	J	412 52 46-01	Cog wheel, large	M,N
412 32 50-02	Spring holder	J	412 52 48-01	Holder, X-cog belt	M
412 32 71-45	Transformer 220-240 V	B	412 52 49-01	Adjuster, belt tension	M
412 32 71-47	Transformer 120 V	B	412 52 53-01	Holder, Y-cog belt	N
412 32 71-48	Transformer 100 V	B	412 52 54-02	Sensor Em. Frame	N
412 32 79-01	Lamp cabel	F	412 52 55-01	Cog belt, Y-unit	M
412 32 84-01	Clamp	G,H	412 52 61-01	Circuit board	N
412 33 62-01	Cog Gear	E	412 52 64-03	Frame Y-unit	N
412 33 93-01	Attachment, motor	B	412 52 65-03	Button	N
412 33 94-01	Muffler, motor	B	412 52 66-01	Spring	N
412 33 97-02	Motor 24 V	B	412 52 67-01	Cog belt	N
412 34 26-03	Spring	B	412 52 71-02	Embroidery hoop 150x240	O
412 34 47-01	Holder	B	412 52 79-01	Cover,Y-unit	N
412 34 50-01	Eccentric	B	412 52 85-01	Guide rail	M
412 34 54-01	Cog belt	G	412 52 97-02	Friction tape	M
412 34 60-01	Stop ring	H	412 52 97-04	Friction tape	L
412 34 81-01	Spring	I	412 53 30-01	Stitch plate	D
412 34 82-01	Setting screw	I	412 53 34-01	Reel pin holder	A
412 34 85-01	Joint cross	I	412 53 37-01	Knob feed dog lowering	A
412 34 88-01	Fastener, spring	I	412 54 02-02	Feeding step motor cpl,	I
412 34 96-01	Cable motor	B	412 54 06-01	Calibration stop	I
412 34 97-01	Cable for PC-board	B	412 54 07-01	Damper	I
412 35 31-01	Thread tension set	J,L	412 54 08-01	Cog wheel	I

Part no	Description	Page	Part no	Description	Page
412 54 10-01	Shaft	I	412 91 44-01	Transport support	M
412 54 37-01	Adjusting Nut	J	412 93 01-01	Spring	D
412 54 56-01	Holder	B	412 93 48-01	Dust cover	D
412 54 64-01	Calibration lever	M,N	412 99 19-01	Main foil key board	A
412 54 65-01	Holder	N	413 02 55-05	Frame - lower	F
412 54 97-01	Tap thread guard	A	413 05 22-01	Clip	F
412 54 98-01	Washer	A	413 23 84-02	Needle threader	F
412 55 01-01	Bobbin case compl.	D			
412 55 39-02	Cable holder, X-unit	M	721 41 69-70	Pin	I
412 55 43-02	Bobbin winding cover cpl.	A	721 41 87-70	Pin	G,H
412 55 57-01	Spring	N	721 42 10-10	Pin	H
412 55 79-01	Bobbin winding excenter	A	725 52 20-05	Screw M3*6	I
412 55 80-01	Thread support	A	725 52 28-05	Screw	F
412 55 81-01	Washer	A	725 52 30-01	Screw	F
412 55 82-01	Cabel X-Y	B	728 52 19-05	Stop screw	F
412 55 83-01	Holder	N	728 52 22-05	Screw	F
412 55 84-01	Damper-upper shaft	G	728 52 83-05	Screw M4*4	C,G,H
412 55 85-01	Connecting board	M	728 52 85-05	Screw M4*6	F
412 56 15-45	Plastic bobbins (10-pac)	D,L	728 52 87-05	Screw M4*8	D
412 56 18-01	Step motor comp.	M	731 23 10-01	Nut	F
412 56 31-01	Thread support	A	734 11 23-71	Washer	J
412 56 39-01	Cover X-unit	M	734 11 25-41	Washer	F
412 56 54-01	Sewing kit Embroidery	O	735 21 36-01	Locking washer	B
412 56 58-01	Zipperbag	O	735 31 06-20	E-ring	J
412 57 97-01	Grip 100x100	O	735 31 08-20	E-ring	D,J,M,N
412 58 17-02	Needle bar compl.	F	735 31 09-20	E-ring	C
412 58 18-01	Needle clamp	F	735 31 10-20	E-ring	M,N
412 58 19-01	Guide	F	735 58 05-10	Locking washer	E
412 59 00-03	Cover	N	735 58 23-00	Locking washer	A
412 60 01-01	Needle bar frame	F	735 58 35-00	Locking washer	A
412 60 03-01	Thread take up	E	735 58 55-00	Washer	G
412 61 92-02	Frame Y-unit	N	735 61 18-40	Circlip 2.5mm	F
412 62 88-01	Shaft	M	735 61 24-40	Circlip 3mm	E,J
412 62 89-01	Shaft	N	735 61 36-40	Circlip 4mm	E
412 62 90-01	Bearing	M	735 61 53-40	Circlip 6mm	E
412 64 89-02	Embroidery d-Card 100-2	O			
412 64 89-05	Embroidery d-Card 100-5	O	ACCESSORIES		
412 65 18-01	Bag with 10 Hoop clips	O	401 53 99-01	Buttonhole knife	
412 65 45-04	Embroidery case	O	401 55 55-01	Brush	
			411 17 32-01	Clearance plate	
412 68 23-10	Front cover Cpl	A	412 08 28-47	Marking pen, neutral	
412 68 25-10	Lid cover	A	412 36 14-01	Opener Stitch plate	
412 68 29-01	Support	D	412 38 15-01	Screw driver	
412 68 31-02	Back cover	A	412 39 77-01	Thread net	
412 68 32-01	Free arm cover	A	412 56 15-45	Bobbins (10)	
412 68 34-01	Handle	A	412 57 01-01	Sleeve, lamp	
412 68 36-02	Base cover	B	412 61 07-01	Felt pad	
412 68 37-01	Hard cover	L	412 62 09-01	Grip aid for hoops	
412 68 38-01	Accessory box	L			
412 68 47-01	Presser bar guide cpl.	F	PRESSERFEET		
412 68 48-01	Frame	E	412 76 40-01	Presser foot A	
412 68 50-01	Regulating dial	E	412 78 54-45	Presser foot B	
412 68 51-01	Spring-Presser bar	F	412 78 53-45	Buttonhole foot C	
412 68 52-01	Presser bar lifter	E	412 38 04-45	Presser foot D	
412 68 63-01	Feed dog compl.	C	412 80 15-45	Zipper foot E	
412 68 72-01	Shaft-feed dog lowering	A	412 38 06-45	Presser foot J	
412 69 31-01	Window / Front cover	A	412 72 76-01	Embroidery foot U	
412 69 36-01	Spring	E	412 81 51-01	Sensor Buttonhole foot	
412 69 37-01	Screen	A			
412 69 51-01	Thread guide	A	MANUALS		
			412 99 27-01	Users Guide Swe	
412 69 65-01	Connector sensor foot with cable	E	412 99 27-06	Users Guide Dan	
412 69 87-01	Adjusting arm	B	412 99 27-07	Users Guide Isl	
412 69 93-01	Adjustment dial	J	412 99 27-10	Users Guide Jap	
412 69 94-02	Thread tension unit Cpl.	J	412 99 27-11	Users Guide Fin	
412 69 97-01	Screen - Stopright func	H	412 99 27-21	Users Guide Nor	
412 70 08-01	Thread guide	A	412 99 27-26	Users Guide Eng	
412 70 17-02	D-card holder	A	412 99 27-31	Users Guide Fra	
412 70 74-01	Cover X-Y port	A	412 99 27-36	Users Guide Holl	
412 70 80-01	Accessory box	L	412 99 27-41	Users Guide Ita	
412 70 81-01	Cover accessory box	L	412 99 27-46	Users Guide Spa	
412 70 82-01	Locking snap, Acc box	L	412 99 27-51	Users Guide Germ	
412 70 83-01	Inside tray, Acc box	L	412 99 27-56	Users Guide Rus	
412 70 98-01	Spring	L	412 99 27-58	Users Guide Est	
412 71 80-46	PC-board Platinum 955E	B	412 99 27-82	Users Guide Pol	
412 71 92-01	Micro switch	E	412 99 27-90	Users Guide Cz	
412 72 02-01	Upper cover, X-unit	M	413 00 61-01	Owners Handbook Swe	
412 72 03-01	Lower cover, X-unit	M	413 00 61-06	Owners Handbook Dan	
412 72 04-01	Step motor cover, Y-unit	M	413 00 61-07	Owners Handbook Isl	
412 72 05-01	Locker, Embroidery unit	M	413 00 61-10	Owners Handbook Jap	
412 72 14-01	Spring	M	413 00 61-11	Owners Handbook Fin	
			413 00 61-21	Owners Handbook Nor	
412 72 89-01	Attachment stepmotor	J	413 00 61-26	Owners Handbook Eng	
412 73 23-01	Screw	F	413 00 61-31	Owners Handbook Fra	
412 74 98-01	Sensor Em. Frame	N	413 00 61-36	Owners Handbook Holl	
412 75 31-01	Hook cover	D	413 00 61-41	Owners Handbook Ita	
412 76 68-01	Plastic bag with access. Platinum	L	413 00 61-46	Owners Handbook Spa	
412 76 85-05	Sewing head compl.	E	413 00 61-51	Owners Handbook Germ	
412 77 34-01	Foot control compl.	K	413 00 61-56	Owners Handbook Rus	
412 82 49-02	Foil key board sewing head	A	413 00 61-58	Owners Handbook Est	
412 82 91-01	Washer	H	413 00 61-90	Owners Handbook Cz	
412 82 91-03	Washer	C			
412 86 68-01	Grease protector	D	CD		
412 86 69-01	Hook shaft	D	412 85 52-95	3D Software Demo CD	
412 87 67-01	Washer	F	413 00 62-96	Instruction CD Platinum 775/955E	
412 87 68-01	Plastic holder	F			
412 87 69-01	Hook	D			
412 87 88-01	d-Card holder Cpl.	A			
412 88 14-01	Design Book Platinum 955E	O			
412 90 89-01	Spring	C			

A

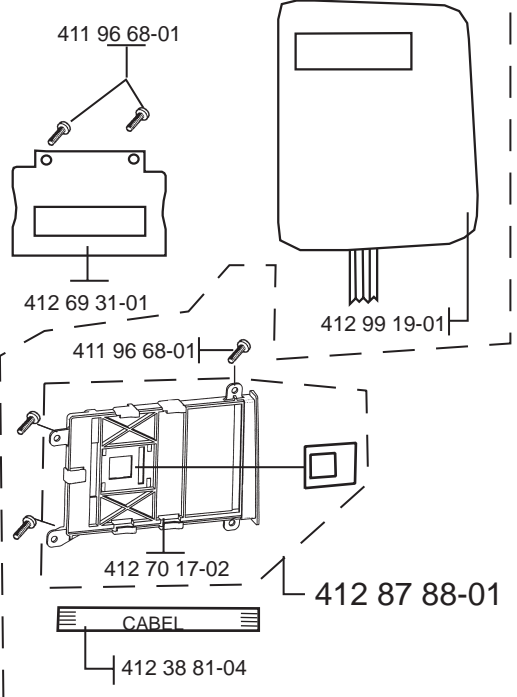
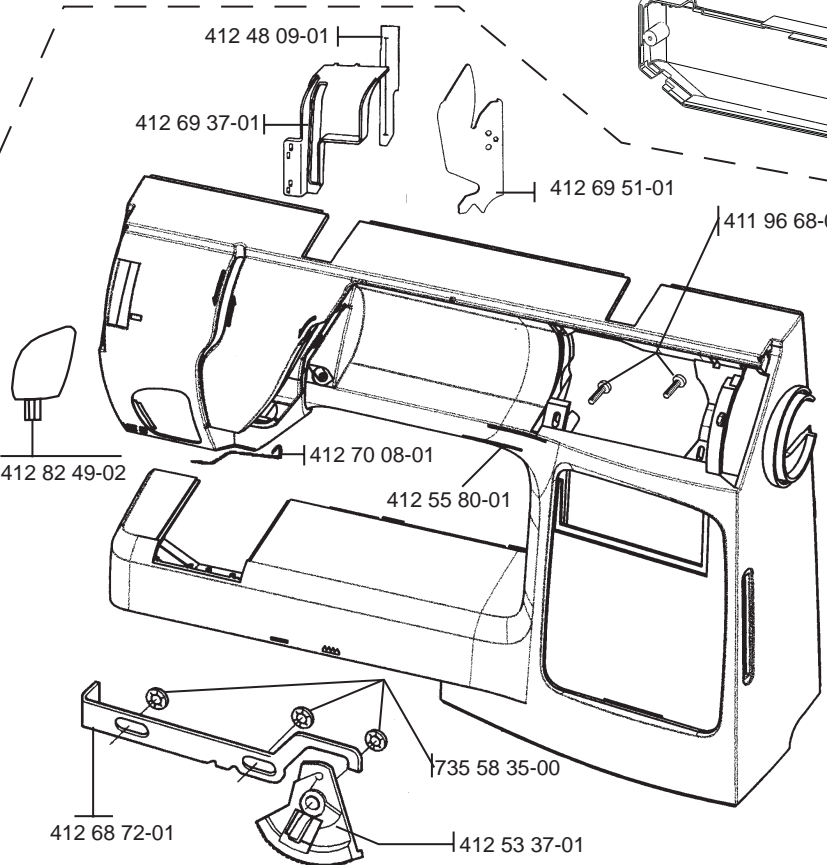
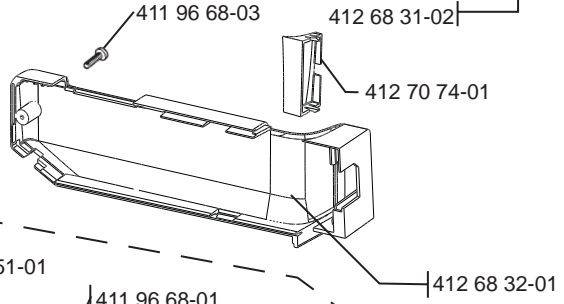
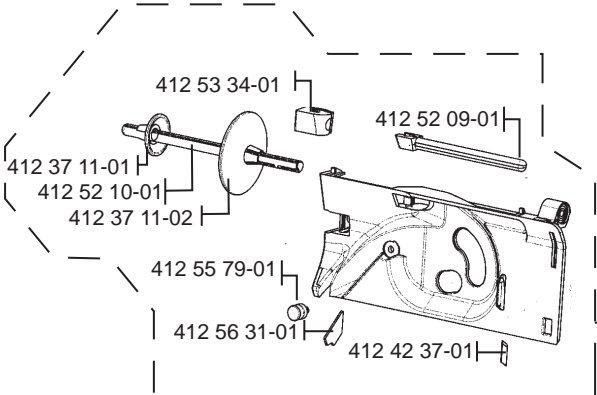
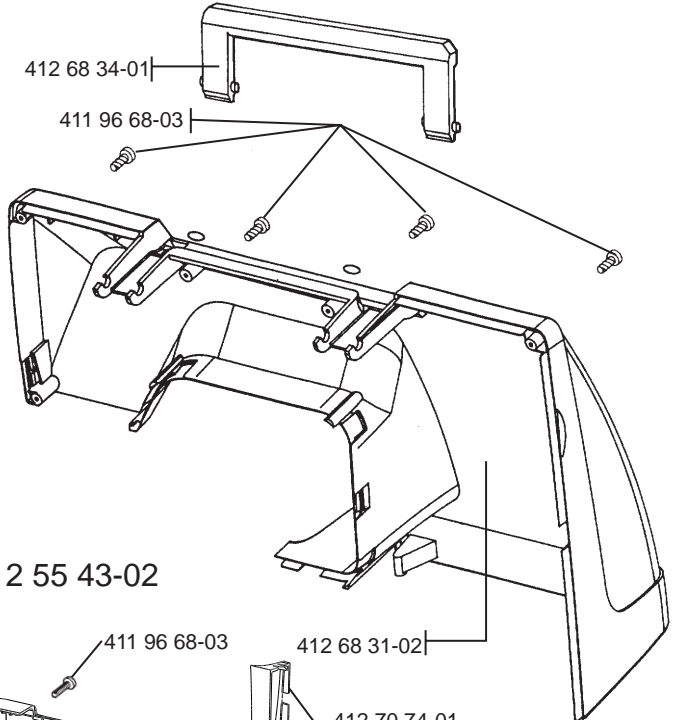
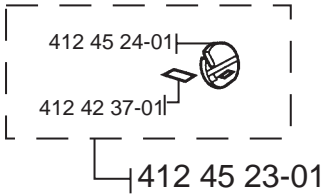

- 412 54 97-01
- 412 52 14-01
- 412 54 98-01
- 412 55 81-01
- 735 58 23-00

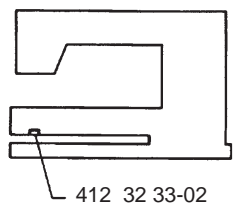
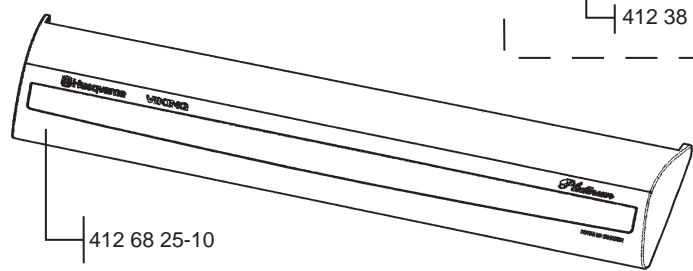

412 68 23-10

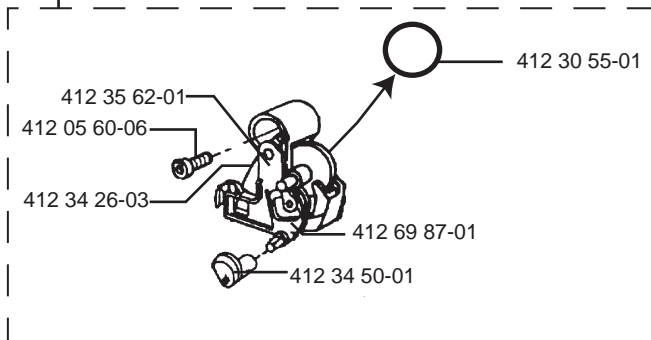
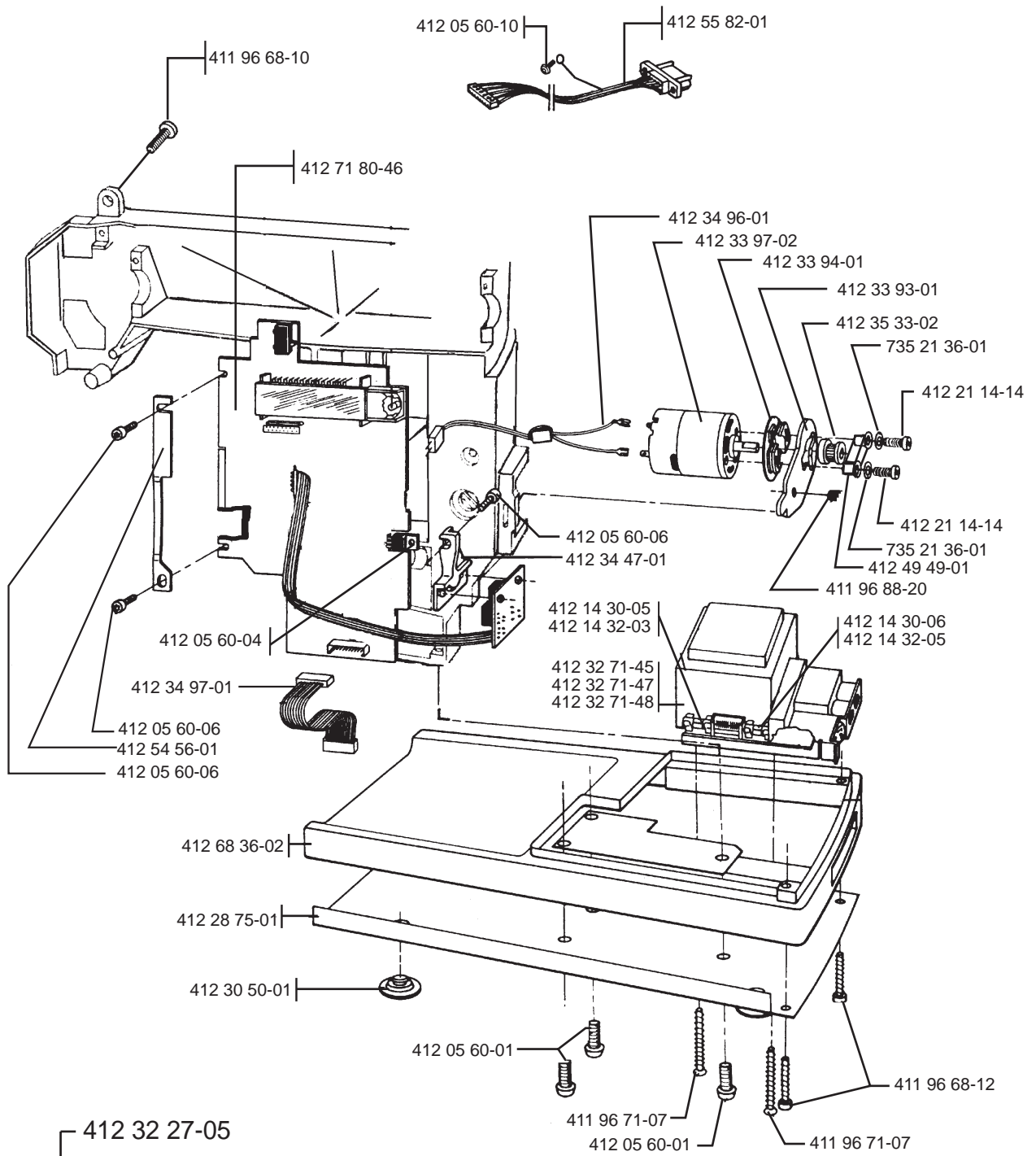

C

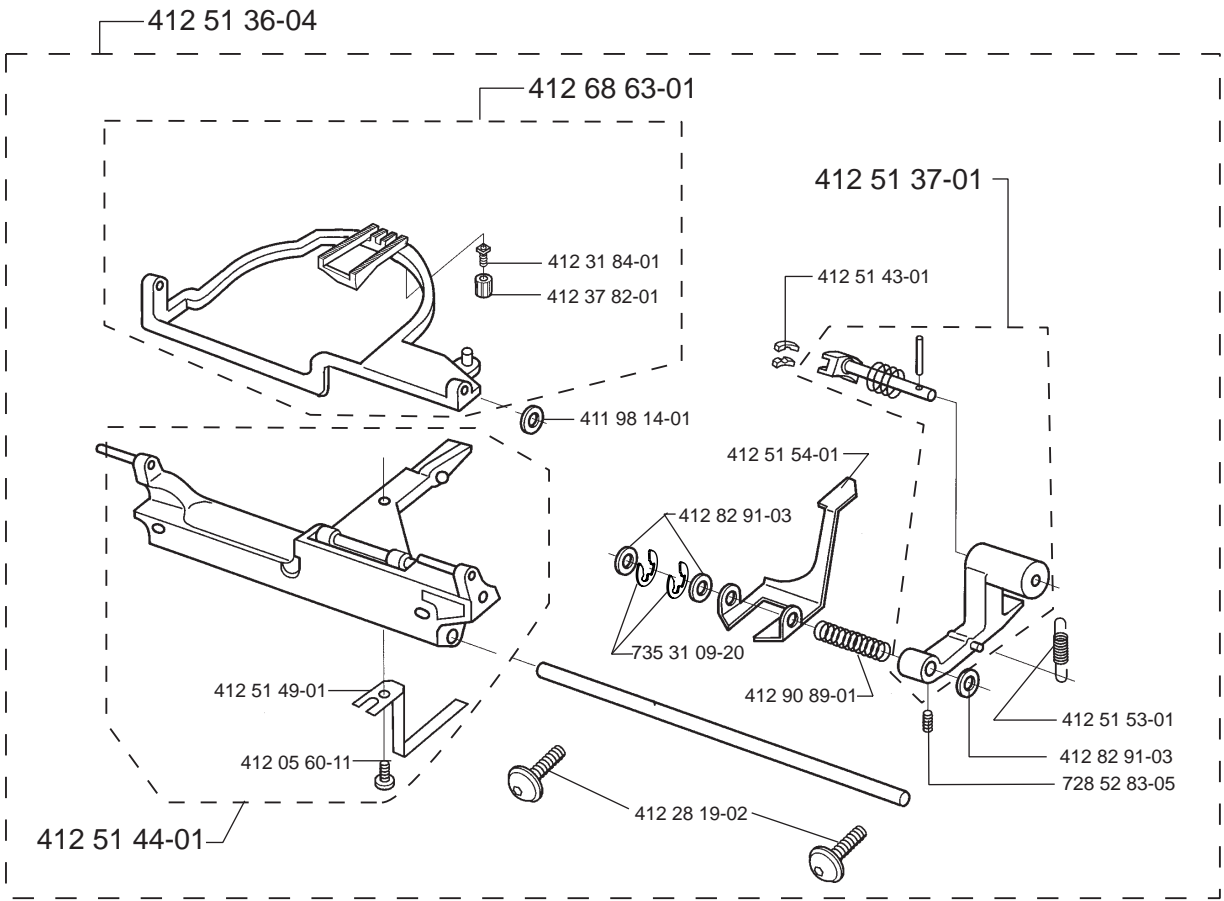

D

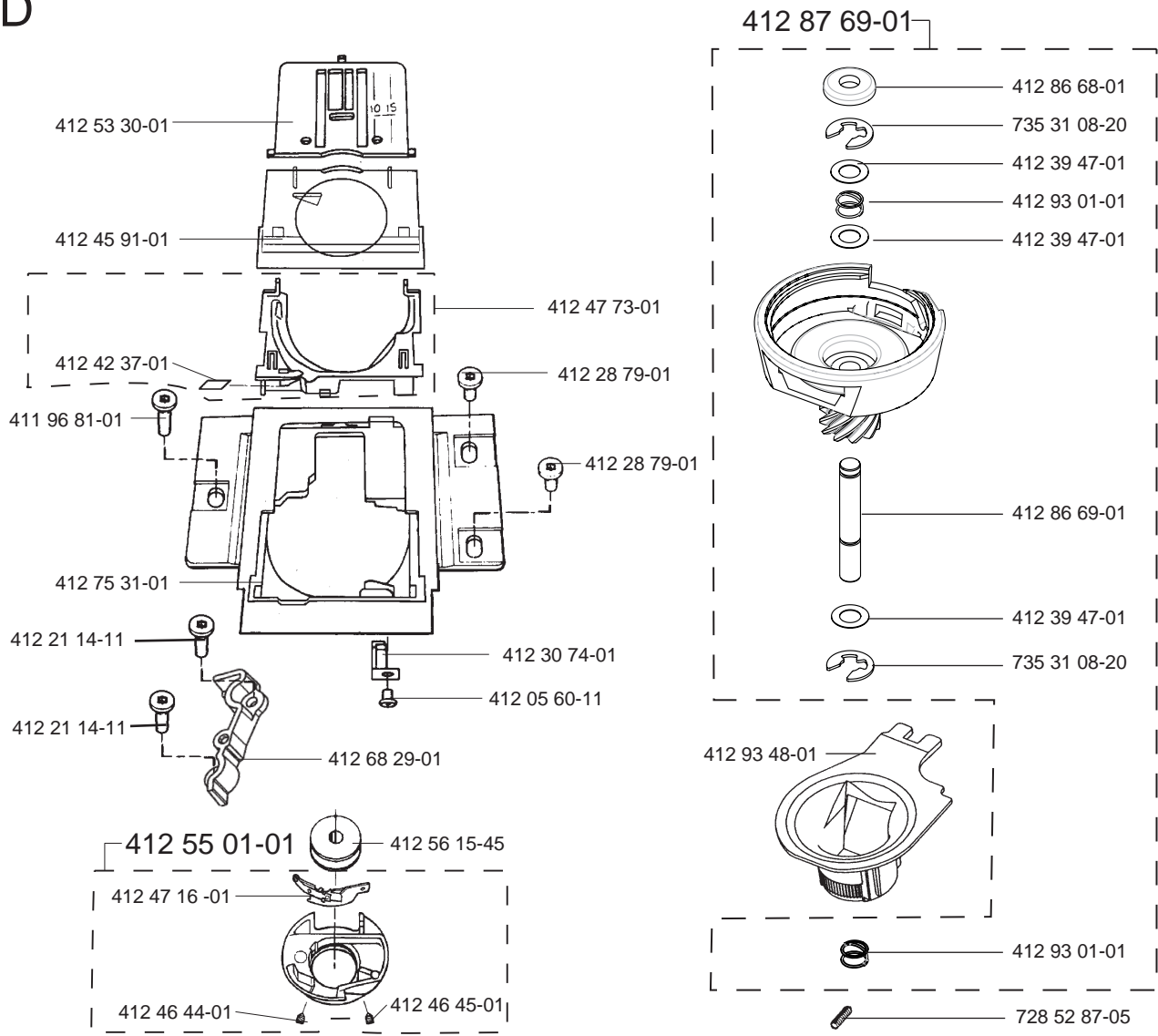

412 76 85-05

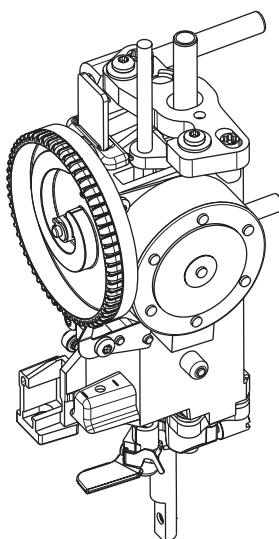

735 61 24-40

412 68 50-01

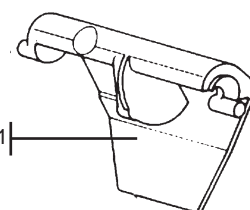

412 68 52-01

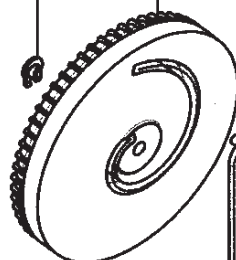

412 39 12-01

412 68 48-01

735 58 05-10

411 96 68-21

412 69 65-01

412 50 48-01

412 50 06-01

412 28 19-02

411 96 68-04

412 69 36-01

411 96 68-01

412 33 62-01

411 96 87-03

412 71 92-01

411 96 68-21

412 50 27-01

735 61 53-40

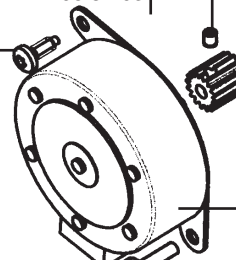

411 96 68-01

412 32 34-10

411 78 10-03



412 30 30-01

735 61 36-40

412 21 14-04

412 60 03-01

F

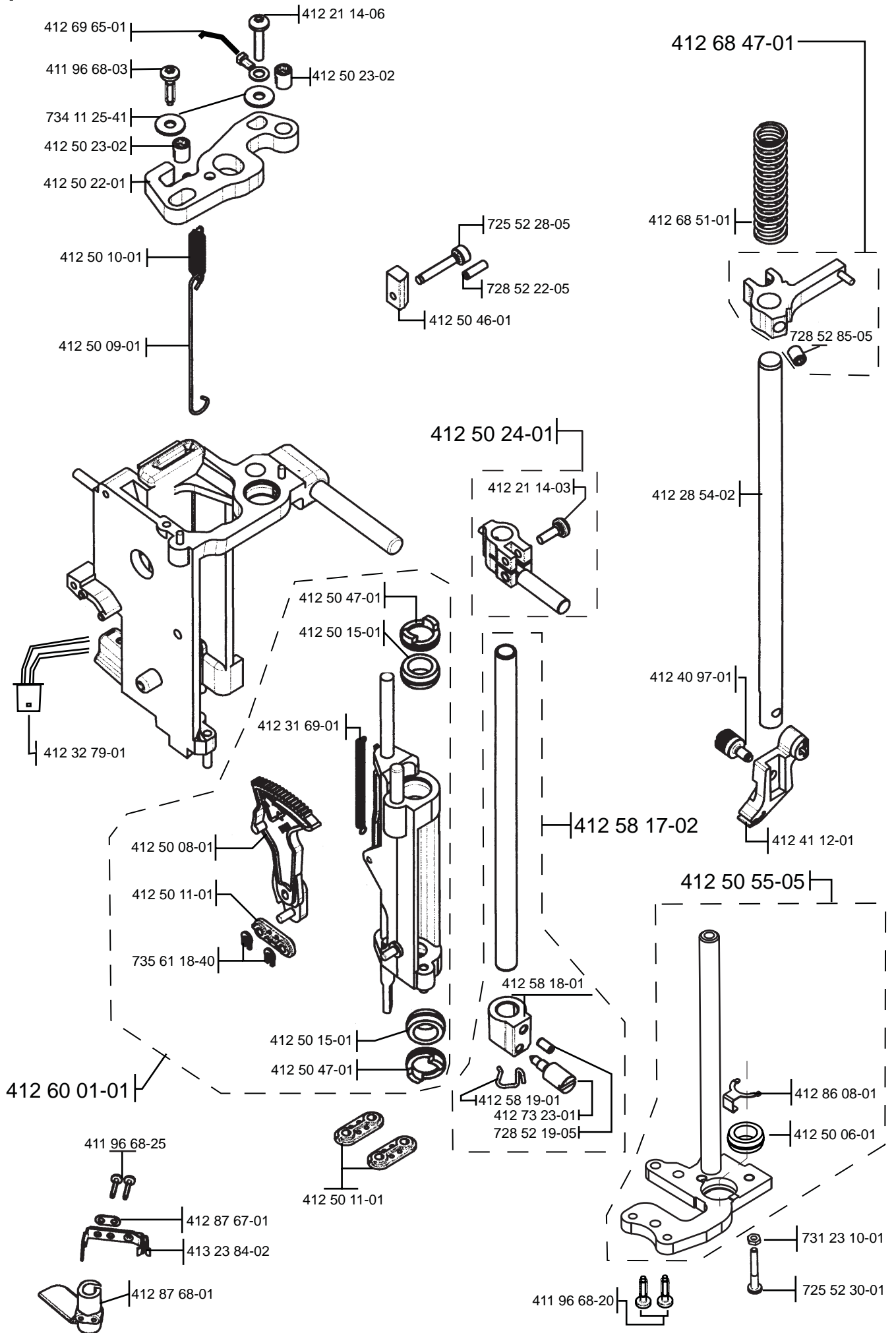

G

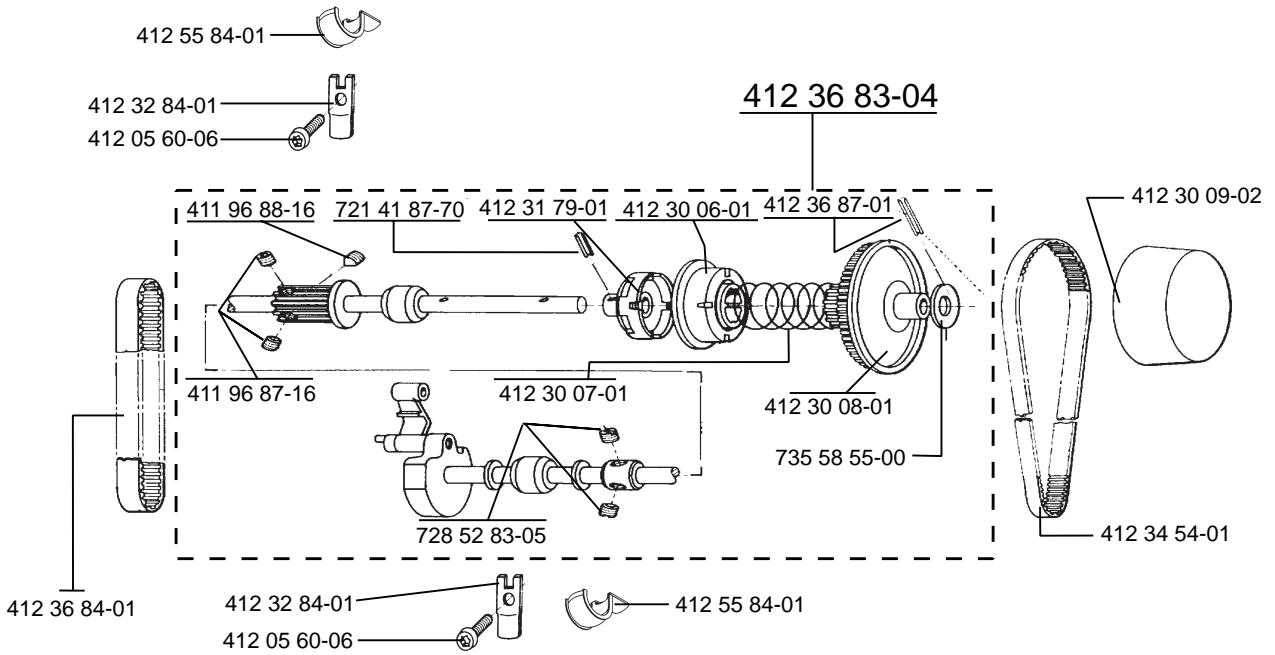

H

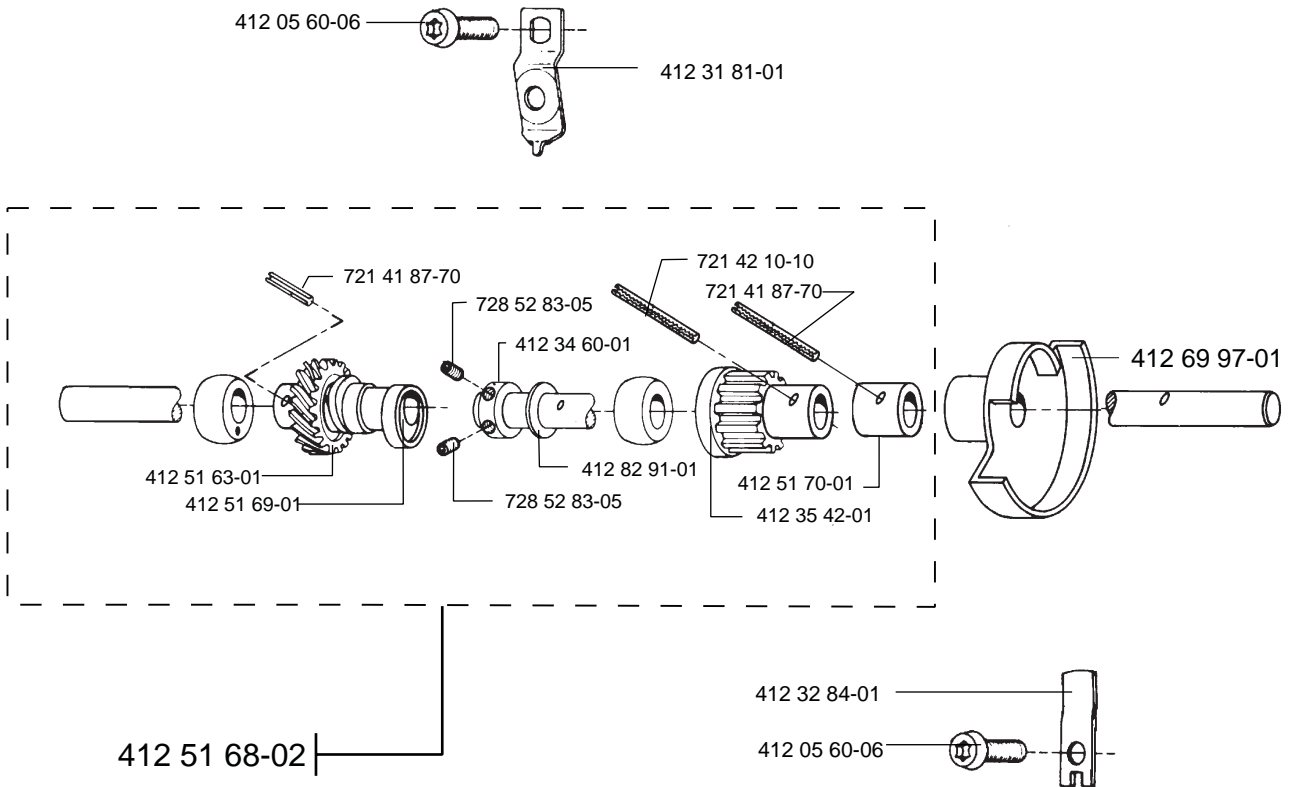

I

412 54 02-02

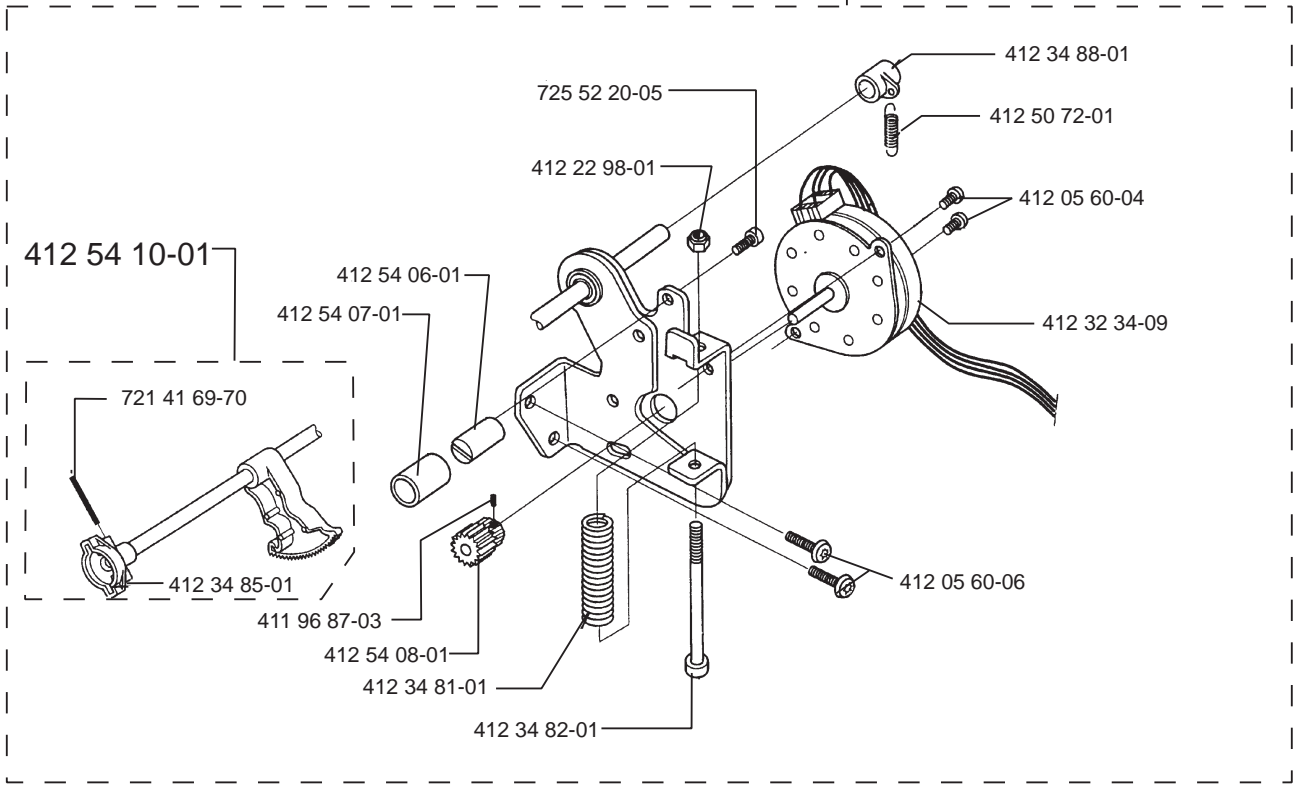

J

412 69 94-02

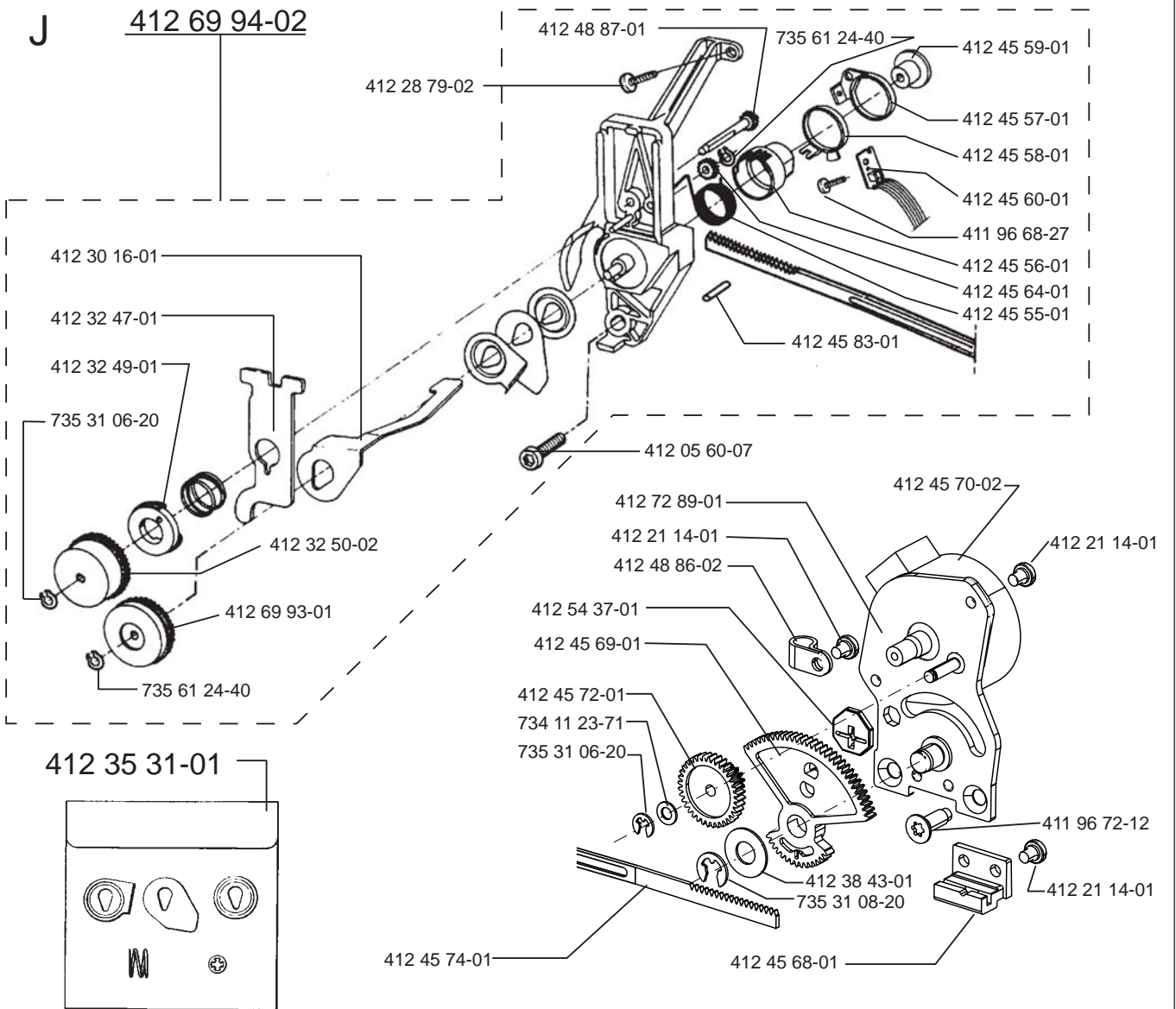

412 35 31-01

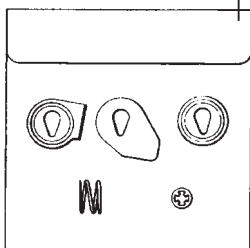

412 77 34-01

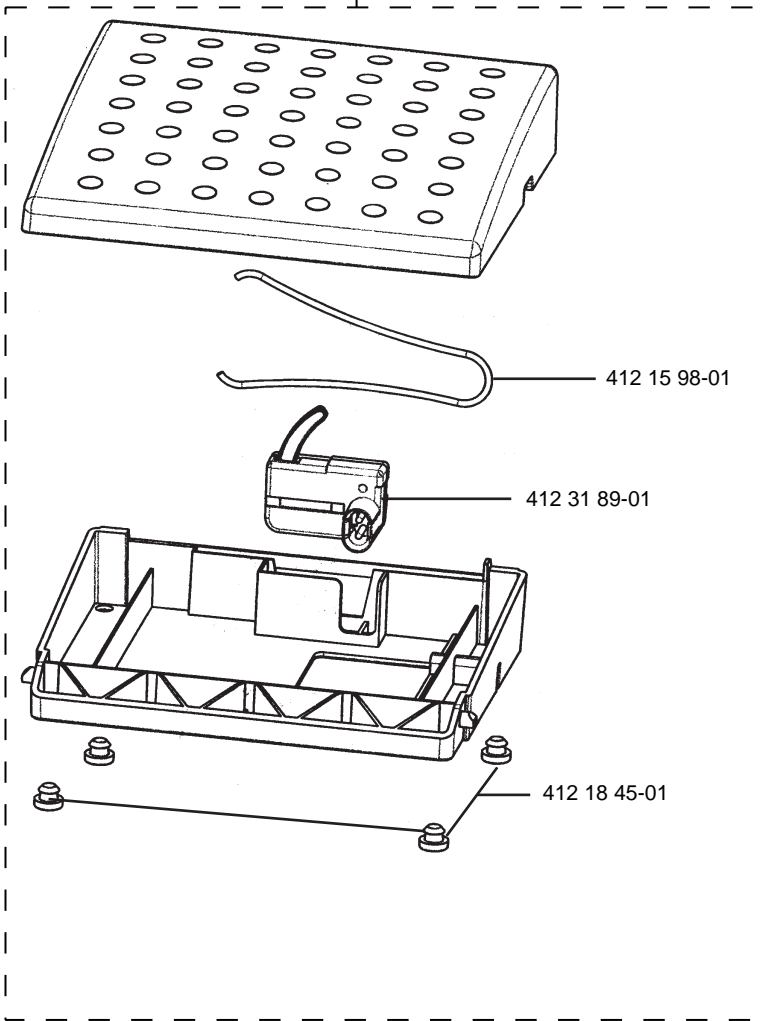

412 15 78-01
412 15 79-02
412 15 79-03
412 15 80-02
412 15 81-01

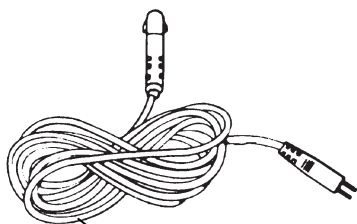
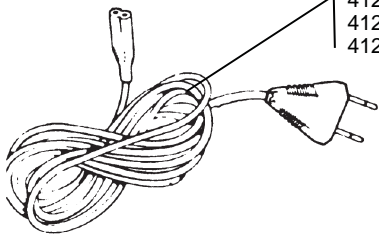

412 31 44-01
412 31 44-02

L

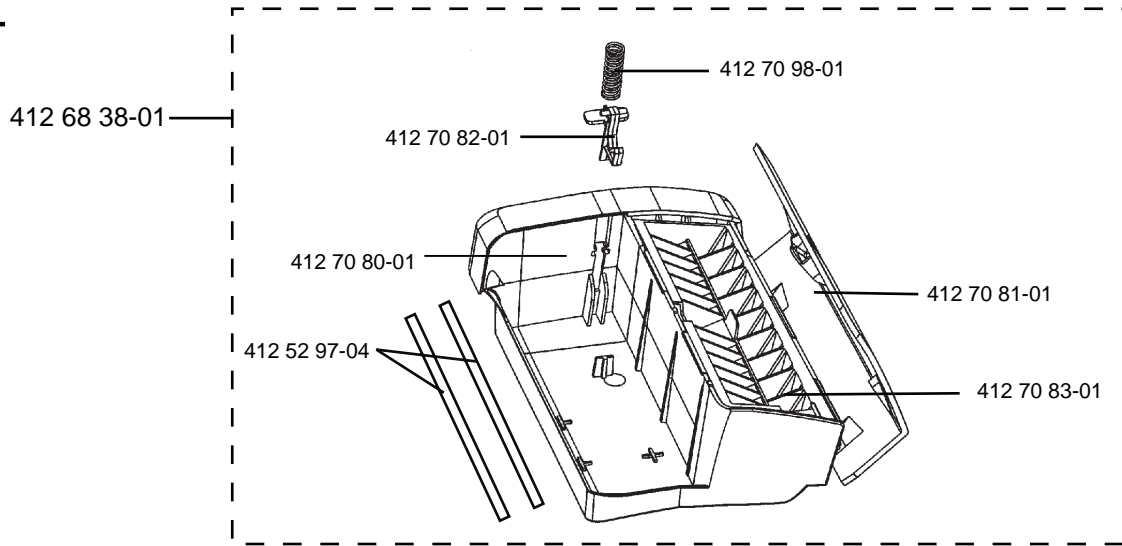

Users Guide

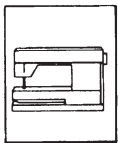

- 412 99 27-01 Users Guide Swe
- 412 99 27-06 Users Guide Dan
- 412 99 27-07 Users Guide Isl
- 412 99 27-10 Users Guide Jap
- 412 99 27-11 Users Guide Fin
- 412 99 27-21 Users Guide Nor
- 412 99 27-26 Users Guide Eng
- 412 99 27-31 Users Guide Fra
- 412 99 27-36 Users Guide Holl
- 412 99 27-41 Users Guide Ita
- 412 99 27-46 Users Guide Spa
- 412 99 27-51 Users Guide Germ
- 412 99 27-56 Users Guide Rus
- 412 99 27-58 Users Guide Est
- 412 99 27-82 Users Guide Pol
- 412 99 27-90 Users Guide Cz

Owners handbook

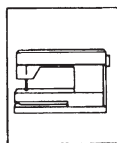

- 413 00 61-01 Owners Handbook Swe
- 413 00 61-06 Owners Handbook Dan
- 413 00 61-07 Owners Handbook Isl
- 413 00 61-10 Owners Handbook Jap
- 413 00 61-11 Owners Handbook Fin
- 413 00 61-21 Owners Handbook Nor
- 413 00 61-26 Owners Handbook Eng
- 413 00 61-31 Owners Handbook Fra
- 413 00 61-36 Owners Handbook Holl
- 413 00 61-41 Owners Handbook Ita
- 413 00 61-46 Owners Handbook Spa
- 413 00 61-51 Owners Handbook Germ
- 413 00 61-56 Owners Handbook Rus
- 413 00 61-58 Owners Handbook Est
- 413 00 61-90 Owners Handbook Cz

CD

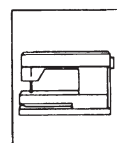

- 412 85 52-95 3D Software Demo CD
- 413 00 62-96 Instruction CD Platinum 755/955E

ACCESSORIES



412 35 31-01
Thread tension
set

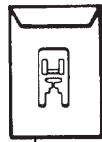

412 76 68-01
Plastic bag
with access.
Platinum 955



412 56 15-45
Plastic bobbins
10 pac

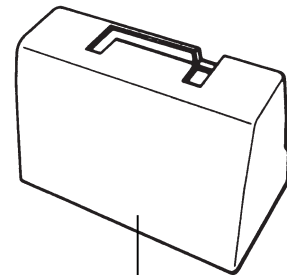

412 68 37-01
Hard cover